

BM.2.50/60/70

- BM** Multi station subplate (supplied in aluminium material)
- 2** CETOP 2/NG4
- ****
 - 50** = Connected in parallel with pressure relief valve and rear connectors
 - 70** = Connected in parallel with pressure relief valve and side connectors
 - 60** = Connected in parallel without pressure relief valve and side connectors
- *** No. of valve seats
2 / 3 / 4 / 5 / 6 / 7 / 8
- C** Type of adjustment (omit for 60 version)
Grub screw
- *** Setting range (omit for 60 version)
 - 1** = max. 30 bar (**white spring**)
 - 2** = max. 90 bar (**yellow spring**)
 - 3** = max. 180 bar (**green spring**)
 - 4** = max. 250 bar (**orange spring**)
- **** **00** = No variant
V1 = Viton
- 1** Serial No.

• The minimum permissible setting pressure depending on the spring:
see cartridge valve type CMP.02...

BM.2.60 CONNECTED IN PARALLEL WITHOUT PRESSURE RELIEF VALVE

Type	A	B	Weight (Kg)
BM.2.60/2	105	91	0,64
BM.2.60/3	145	131	0,87
BM.2.60/4	185	171	1,10
BM.2.60/5	225	211	1,33
BM.2.60/6	265	251	1,56
BM.2.60/7	305	291	1,79
BM.2.60/8	345	331	2,02

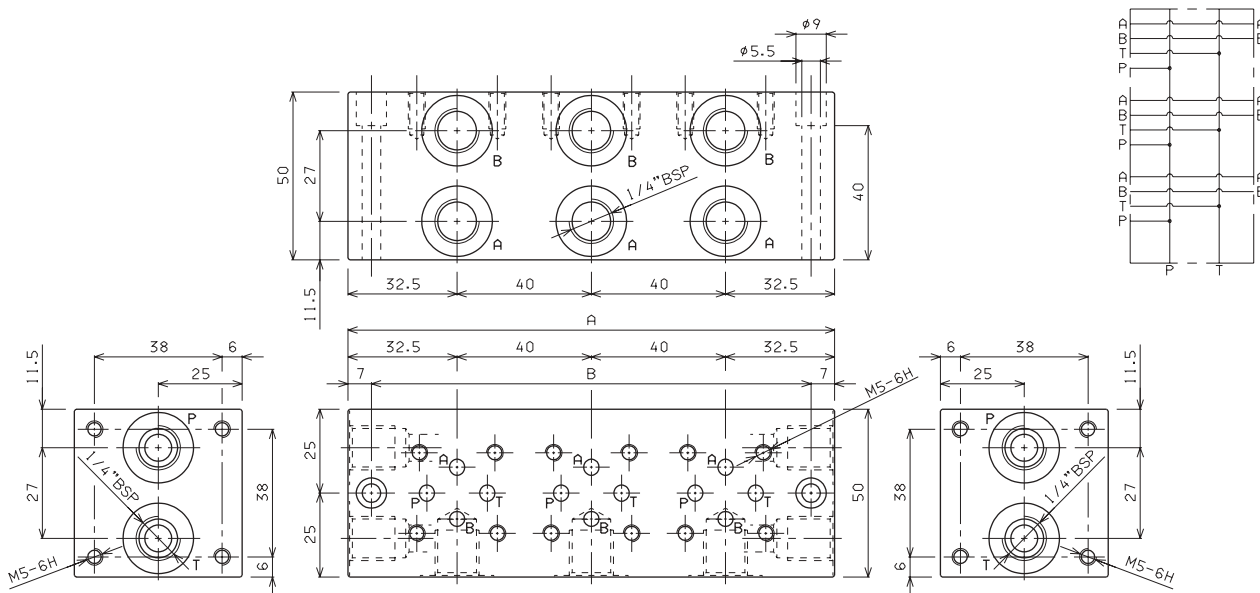

Fixing screws M5x50 UNI 5931

BM.2.50 CONNECTED IN PARALLEL WITH PRESSURE RELIEF VALVE

Type	A	B	Weight (Kg)
BM.2.50/2	130	116	0,70
BM.2.50/3	170	156	0,93
BM.2.50/4	210	196	1,16
BM.2.50/5	250	236	1,39
BM.2.50/6	290	276	1,62
BM.2.50/7	330	316	1,85
BM.2.50/8	370	356	2,08

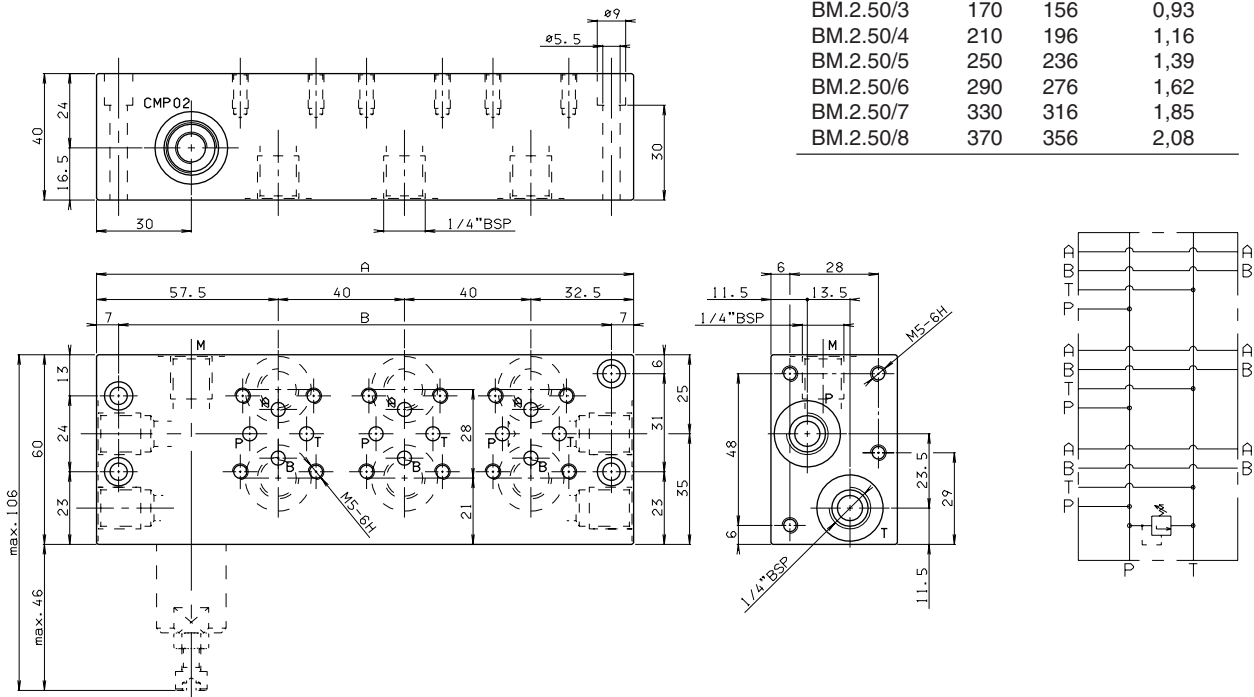

Fixing screws M5x40 UNI 5931

7

BM.2.70 CONNECTED IN PARALLEL WITH PRESSURE RELIEF VALVE

Type	A	B	Weight (Kg)
BM.2.70/2	130	116	0,93
BM.2.70/3	170	156	1,16
BM.2.70/4	210	196	1,39
BM.2.70/5	250	236	1,62
BM.2.70/6	290	276	1,85
BM.2.70/7	330	316	2,08
BM.2.70/8	370	356	2,31

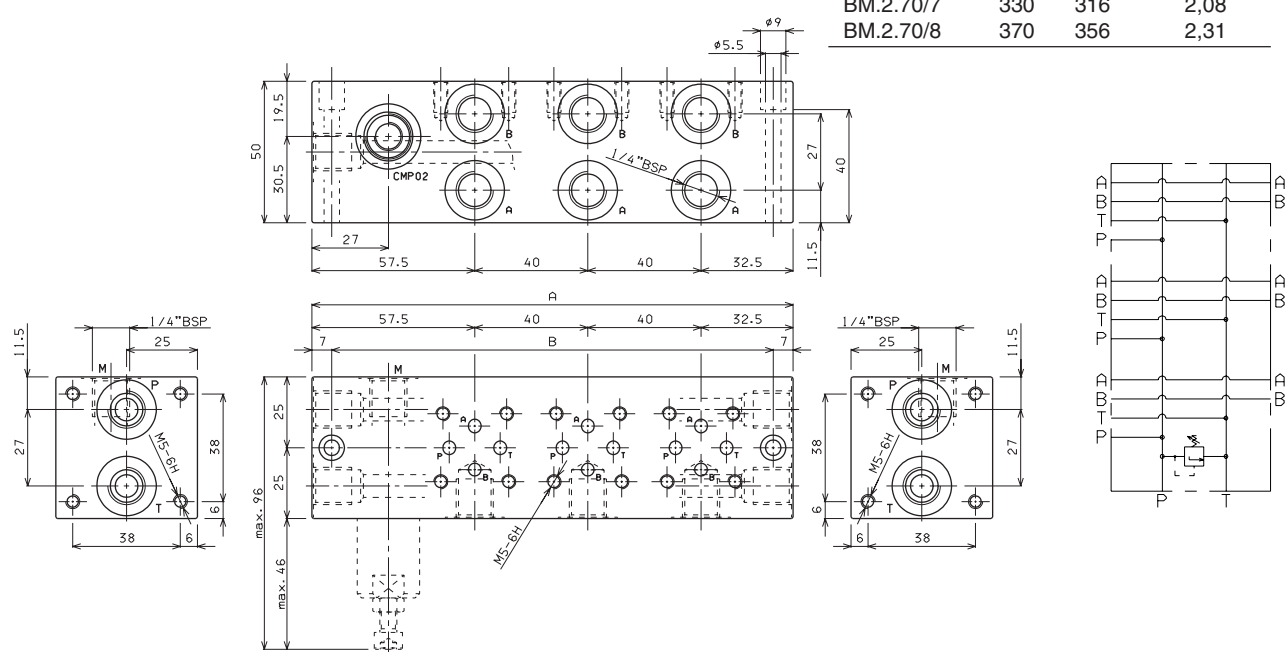

Fixing screws M5x50 UNI 5931