

C3V.05... 3WAY-2POSITION CARTRIDGE SOLENOID VALVES

These cartridge solenoid valves 3way-2position are suitable for off-highway machinery with low pressure performances and a great range of operating temperature.

The voltage supply is available in DC at 12V by connection moulded into the Amp junior or Deutsch with diode bidirectional integrated connectors type.

Max. pressure	250 bar
Max. operating pressure	20 l/min
Duty cycle	100% ED
Hydraulic fluids	Mineral or synthetic oils with lubricating property
Fluid viscosity	5 ÷ 400 mm ² /s
Fluid temperature	-30°C ÷ 120°C
Ambient temperature	-30°C ÷ 100°C
Filter recommended	10 µm nominal value
Type of connection	Amp Junior
Type of protection	IP 65
Weight (with coil)	0,34 Kg
Tightening torque:	
Cartridge	25 ÷ 30 Nm / 2.5 ÷ 3 Kgm
Coil ring nut	4,5 Nm (0.45 Kgm)

Voltage nominal value	12VDC
Rated power	20 W
Pull in voltage request	9.5 V ÷ 14 V
Max. request voltage to drop out	1 V



C3V.05...NR1

ORDERING CODE

- C3V** Cartridge solenoid valve 3way-2position
- 05** 20W Coil
- 1D** Scheme (see hydraulic symbol)
- D** Seat
- *** Type of connection
A = Amp Junior
D = Deutsch with bidirectional diode
- L** Voltage: 12V
- NR** Variant: NBR O-ring type
- 1** Serial No.

Flux	Pressure drops	Limit of use
2 → 1	A	A
2 → 3	B	A
3 → 2	B	B

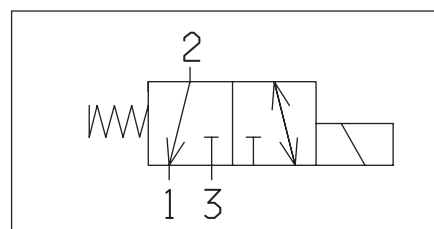

PRESSURE DROPS

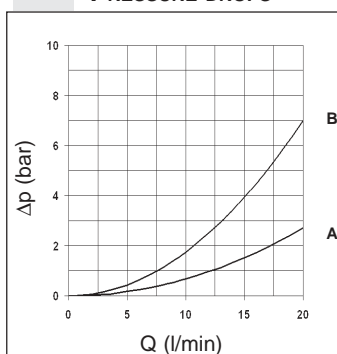

LIMIT OF USE

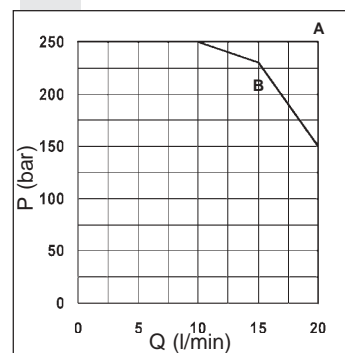

The tests were carried out with the solenoids at operating temperature, with a supply voltage 10% below nominal value and with a 40°C fluid temperature. The fluid used is a mineral oil with a viscosity of 46 mm²/s at 40°C.

OVERALL DIMENSIONS

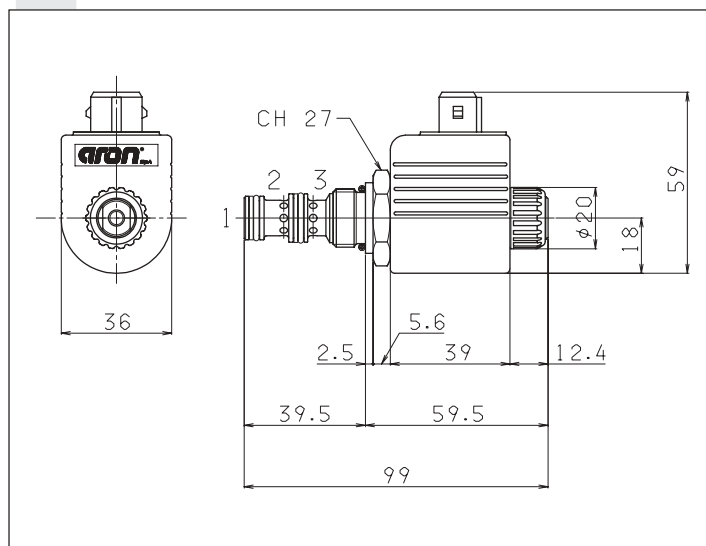

VALVE SEAT DIMENSIONS

