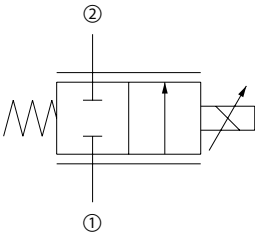
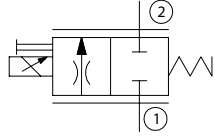
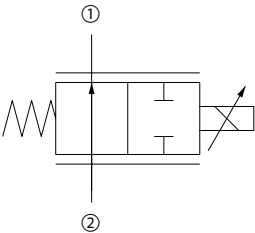
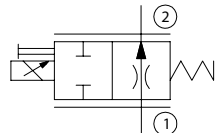
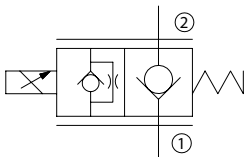

Symbol	Model No.	Cavity	Description	Flow*	Pressure	Page
	CP518-PNC	SDC08-2	Proportional flow control, direct-acting, normally-closed	12 l/min [3 US gal/min]	210 bar [3000 psi]	11.12

Symbol	Model No.	Cavity	Description	Flow*	Pressure	Page
	PSV10-NC	SDC10-2	Proportional flow control, direct-acting, normally-closed	40 l/min [11 US gal/min]	260 bar [3770 psi]	11.13
	PSV12-NC	SDC12-2		80 l/min [21 US gal/min]	260 bar [3770 psi]	11.14
	PSV16-NC	SDC16-2		100 l/min [26 US gal/min]	260 bar [3770 psi]	11.15

Symbol	Model No.	Cavity	Description	Flow*	Pressure	Page
	CP518-PNO	SDC08-2	Proportional flow control, direct-acting, normally-open	12 l/min [3 US gal/min]	210 bar [3000 psi]	11.16

Symbol	Model No.	Cavity	Description	Flow*	Pressure	Page
	PSV10-NO	SDC10-2	Proportional flow control, direct-acting, normally-open	45 l/min [12 US gal/min]	260 bar [3770 psi]	11.17
	PSV12-NO	SDC12-2		100 l/min [26 US gal/min]	260 bar [3770 psi]	11.18
	PSV16-NO	SDC16-2		110 l/min [29 US gal/min]	260 bar [3770 psi]	11.19

Symbol	Model No.	Cavity	Description	Flow*	Pressure	Page
	PSVP10-NCR	SDC10-2	Proportional flow control, pilot-operated, normally-closed	55 l/min [14 US gal/min]	260 bar [3770 psi]	11.20
	PSVP12-NCR	SDC12-2		70 l/min [18 US gal/min]	260 bar [3770 psi]	11.21
	PSVP16-NCR	SDC16-2		90 l/min [24 US gal/min]	260 bar [3770 psi]	11.22

* Flow ratings are based on a pressure drop of 7 bar [100 psi] unless otherwise noted. They are for comparison purposes only.

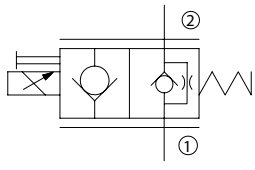
Symbol	Model No.	Cavity	Description	Flow*	Pressure	Page
	PSVP10-NOR	SDC10-2	Proportional flow control, pilot-operated, normally-open	45 l/min [12 US gal/min]	260 bar [3770 psi]	11.23
	PSVP12-NOR	SDC12-2		70 l/min [18 US gal/min]	260 bar [3770 psi]	11.24
	PSVP16-NOR	SDC16-2		80 l/min [21 US gal/min]	260 bar [3770 psi]	11.25

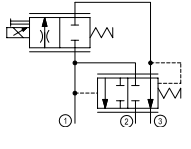
Symbol	Model No.	Cavity	Description	Flow*	Pressure	Page
	PFC10-PC	SDC10-3	Proportional flow control, priority-type, normally-closed	40 l/min [11 US gal/min]	260 bar [3770 psi]	11.26
	PFC12-PC	SDC12-3		65 l/min [17 US gal/min]	260 bar [3770 psi]	11.27
	PFC16-PC	SDC16-3		85 l/min [22 US gal/min]	260 bar [3770 psi]	11.28

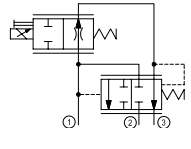
Symbol	Model No.	Cavity	Description	Flow*	Pressure	Page
	PFC10-PO	SDC10-3	Proportional flow control, priority-type, normally-open	35 l/min [9 US gal/min]	260 bar [3770 psi]	11.29
	PFC12-PO	SDC12-2		70 l/min [18 US gal/min]	260 bar [3770 psi]	11.30
	PFC16-PO	SDC16-3		90 l/min [24 US gal/min]	260 bar [3770 psi]	11.31

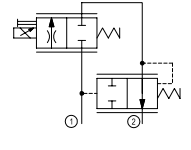
Symbol	Model No.	Cavity	Description	Flow*	Pressure	Page
	PFC10-RC	SDC10-2	Proportional flow control, restrictive-type, normally-closed	30 l/min [8 US gal/min]	260 bar [3770 psi]	11.32
	PFC12-RC	SDC12-2		65 l/min [17 US gal/min]	260 bar [3770 psi]	11.33
	PFC16-RC	SDC16-2		90 l/min [24 US gal/min]	260 bar [3770 psi]	11.34

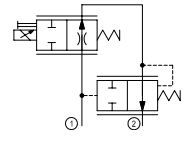
Symbol	Model No.	Cavity	Description	Flow*	Pressure	Page
	PFC10-RO	SDC10-2	Proportional flow control, restrictive-type, normally-open	30 l/min [8 US gal/min]	260 bar [3770 psi]	11.35
	PFC12-RO	SDC12-2		60 l/min [16 US gal/min]	260 bar [3770 psi]	11.36
	PFC16-RO	SDC16-2		85 l/min [22 US gal/min]	260 bar [3770 psi]	11.37

* Flow ratings are based on a pressure drop of 7 bar [100 psi] unless otherwise noted. They are for comparison purposes only.

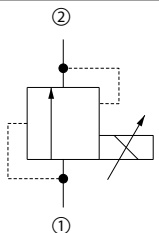
Symbol	Model No.	Cavity	Description	Flow*	Pressure	Page
	XMD 04	NCS04/2	Proportional relief valve (normally open)	5 l/min [1 US gal/min]	250 bar [3600 psi]	11.38
	CP558-20	SDC08-2		8 l/min [2 US gal/min]	210 bar [3000 psi]	11.39

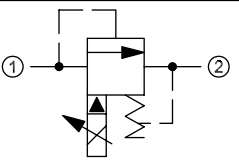
Symbol	Model No.	Cavity	Description	Flow*	Pressure	Page
	XMP 06	NCS06/2	Proportional relief valve (normally open)	50 l/min [13 US gal/min]	315 bar [4500 psi]	11.40

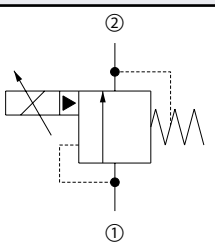
Symbol	Model No.	Cavity	Description	Flow*	Pressure	Page
	PRV10	SDC10-2	Proportional relief valve (normally closed)	76 l/min [20 US gal/min]	250 bar [3600 psi]	11.41
	PRV12	SDC12-2		180 l/min [48 US gal/min]	250 bar [3600 psi]	11.42

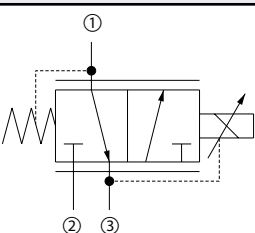
Symbol	Model No.	Cavity	Description	Flow*	Pressure	Page
	XRP 06	NCS06/3	Proportional pressure reducing/relieving valve	25 l/min [7 US gal/min]	315 bar [4500 psi]	11.43
	CP558-24	SDC08-3		4 l/min [1 US gal/min]	34 bar [500 psi]	11.44

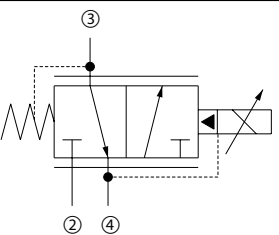
Symbol	Model No.	Cavity	Description	Flow*	Pressure	Page
	XRP 044	SDC10-4	Proportional pressure reducing/relieving valve	25 l/min [7 US gal/min]	50 bar [700 psi]	11.45

* Flow ratings are based on a pressure drop of 7 bar [100 psi] unless otherwise noted. They are for comparison purposes only.

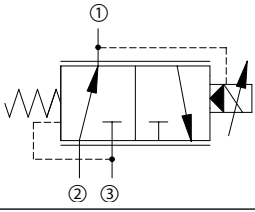
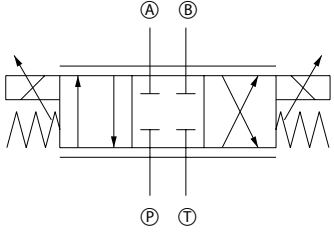
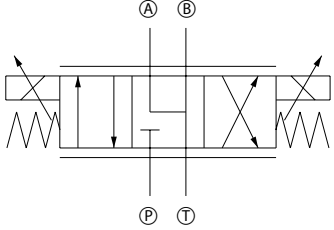
Symbol	Model No.	Cavity	Description	Flow*	Pressure	Page
	PPR10-PAC	SDC10-3	Proportional pressure-reducing/relieving valve	18 l/min [5 US gal/min]	250 bar [3625 psi]	11.46
	PSV10-34-02	SDC10-4	Proportional directional valve	22 l/min [6 US gal/min]	250 bar [3600 psi]	11.47
	P-DCV03-3Z11	ISO D03		30 l/min [8 US gal/min]	320 bar [4640 psi]	11.48
	P-DCV05-3Z11	ISO D05		60 l/min [16 US gal/min]	320 bar [4600 psi]	11.49
	PSV10-34-05	SDC10-4	Proportional directional valve	22 l/min [6 US gal/min]	250 bar [3600 psi]	11.50
	P-DCV03-3Y11	ISO D03		30 l/min [8 US gal/min]	320 bar [4640 psi]	11.51
	P-DCV05-3Y11	ISO D05		60 l/min [16 US gal/min]	320 bar [4600 psi]	11.52

* Flow ratings are based on a pressure drop of 7 bar [100 psi] unless otherwise noted. They are for comparison purposes only.

PROPORTIONAL VALVES

Proportional, or electro-proportional valves, provide infinitely variable control of flow, pressure, or direction, in response to a electric input signal.

There are four basic types of Sauer-Danfoss proportional valves:

- Flow control valves.
- Pressure reducing/relieving valves.
- Pressure relief valves.
- Directional control valves

Proportional valves

F102 011

PLUS+1™ COMPLIANT

Sauer-Danfoss solenoid valves are PLUS+1™ compliant. PLUS+1 compliance means our valves are directly compatible with the PLUS+1 machine control architecture. Adding solenoid valves to your application using PLUS+1 GUIDE software is as easy as *drag-and-drop*. Software development that used to take months can now be done in just a few hours. For more information on PLUS+1 GUIDE, visit www.sauer-danfoss.com/plus1. The table below details available GUIDE function blocks for controlling Sauer-Danfoss solenoid valves.

GUIDE function blocks

Two-way proportional	10106103
Three-way proportional	10106104

PROPORTIONAL FLOW CONTROL VALVES

Sauer-Danfoss proportional flow control valves are 2-way, spool-type valves that are directly operated with a proportional electromagnetic solenoid actuator. By controlling electric current, these valves create an infinitely variable orifice.

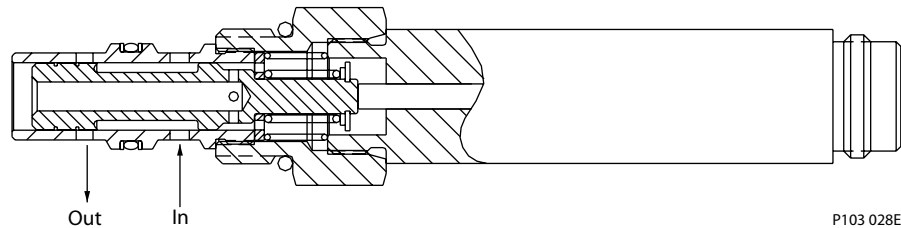
Proportional flow control valve

These valves are designed to be used with a logic element to provide pressure compensation. Pressure compensation provides two advantages:

1. A constant pressure differential is maintained across the proportional valve (variable orifice), which maintains constant flow regardless of changes in operating pressure or load.
2. A constant pressure differential across the proportional valve limits the flow forces acting on the valve spool. At high flow and pressure, the electromagnetic and spring forces can be insufficient to maintain valve operation without pressure compensation.

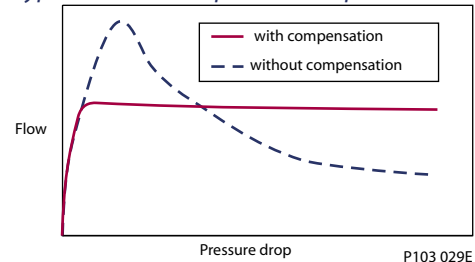
Typical flow versus pressure drop

Typical circuits use restrictive-type or priority-type pressure compensators with proportional flow control valves to control speed of a hydraulic motor or cylinder.

Proportional flow control valves are available with a variety of flow capabilities (variable orifice sizes). By matching this flow capability to various pressure compensator settings, a wide range of flow vs. current control curves can be attained.

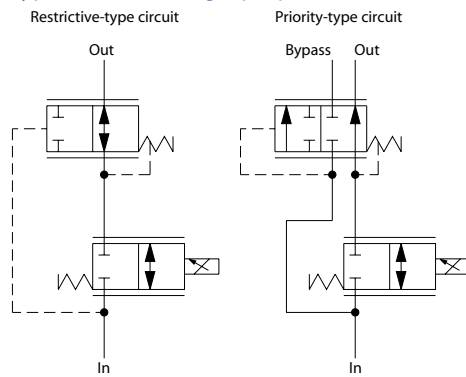
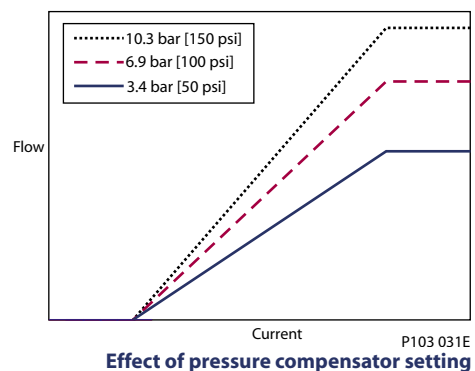
Typical circuit using a proportional valve

Flow versus current

Effect of pressure compensator setting

PROPORTIONAL PRESSURE REDUCING/ RELIEVING VALVES

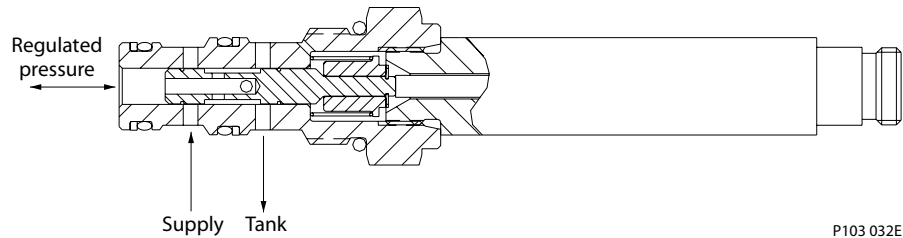
Proportional pressure reducing/relieving valves are 3-way valves that provide a controlled output pressure as a function of electric current, regardless of system pressure or flow (within the valve's limits). Direct acting designs are available for low-flow applications.

Direct-acting, proportional, pressure reducing valve



P103 032E

Proportional pressure reducing valves have a variety of applications including:

- Single acting cylinder position control, e.g. combine header height control.
- Clutch or brake pressure control.
- Pilot signal to a directional control valve. By slowly ramping the current to the proportional valve in this example, a soft-start and soft-stop is attained.

Clutch pressure control

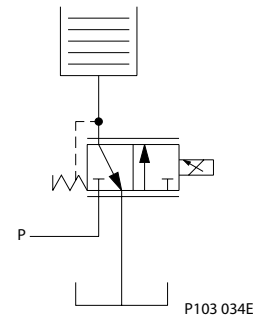

P103 034E

Pilot signal to directional control valve

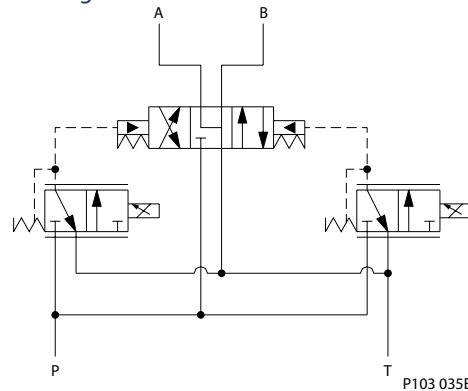

P103 035E

Single-acting cylinder piston control

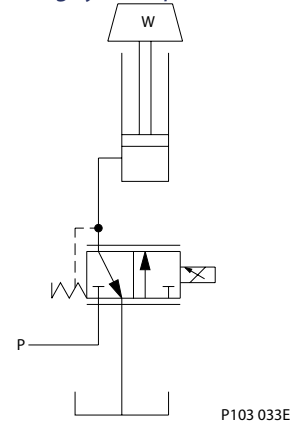

P103 033E

High flow proportional pressure reducing valve functions can be created by using a proportional valve to pilot a differential sensing valve; see differential sensing valve application notes for more information.

PROPORTIONAL PRESSURE RELIEF VALVES

Proportional pressure relief valves are 2-way valves that provide a relief pressure as a function of electric current. Both normally-open (increasing pressure with increasing current), and normally-closed (decreasing pressure with increasing current) are available.

The normally-open proportional relief valve is a direct-acting design for low flow applications. High flow normally-open proportional relief valve functions can be created by using a proportional valve to pilot a differential sensing valve; see differential sensing valve application notes for more information.

Normally closed versus normally open proportional relief valves

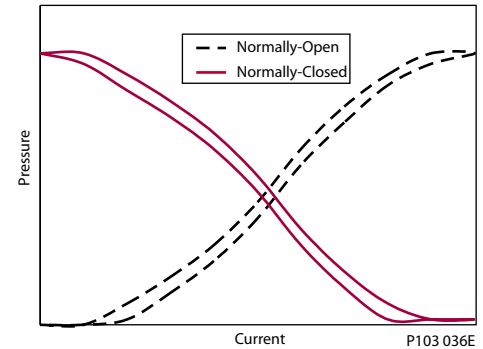

Normally-open proportional relief valve

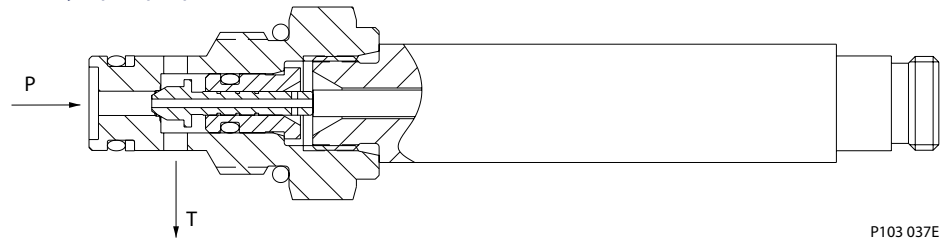

P103 037E

Common applications for normally-open proportional relief valves are:

- Electro-proportional control of system relief pressure; see differential sensing valve application notes for more information.
- Electro-proportional remote pressure compensator control for open circuit piston pumps (for more information refer to BLN-10128 Series 45 Open Circuit Axial Piston Pumps Technical Information).

Remote pressure compensator pump control

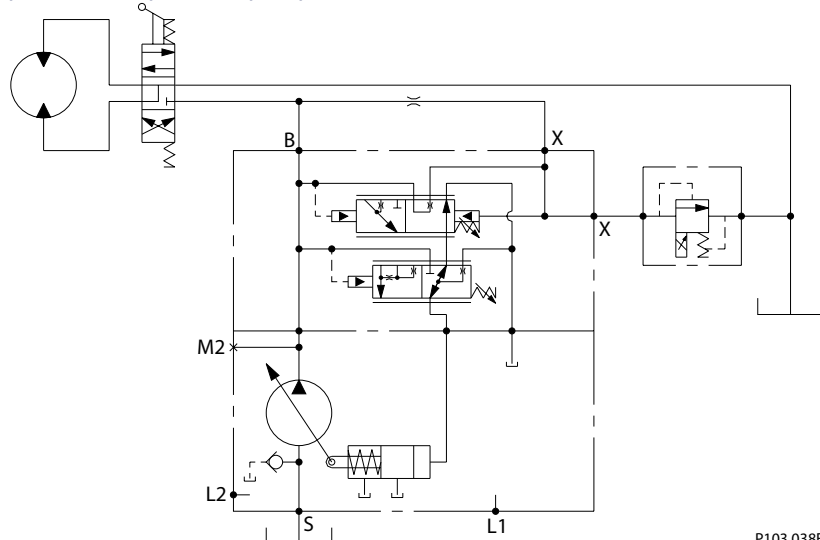

P103 038E

**PROPORTIONAL
 PRESSURE RELIEF VALVES
 (continued)**

Normally-closed proportional relief valves are available in direct-acting and pilot-operated designs. A direct-acting, normally-closed proportional relief valve is used for low flow applications. For high flow applications, internally pilot-operated cartridges are available.

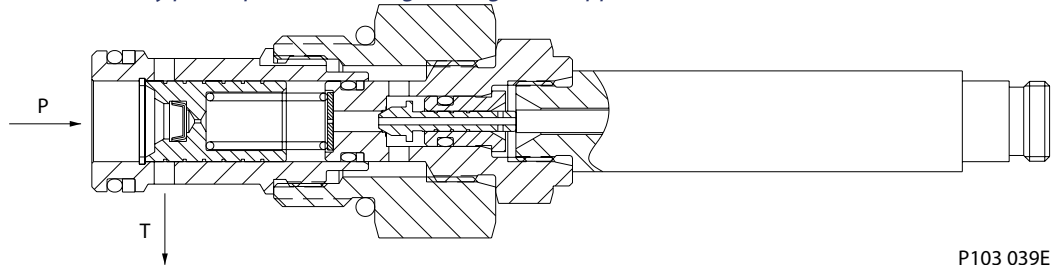
Internally pilot-operated cartridge for high flow applications

P103 039E

Common applications for normally-closed proportional relief valves are:

- Electro-proportional control of system relief pressure or electro-proportional remote pressure compensator control for open circuit piston pumps as above, but where system requirements dictate full pressure with no electrical signal.
- Cooling fan speed control in hydrostatic fan drive systems. (For more information refer to BLN-10080 *Fan Drives Systems and Components Technical Information*).

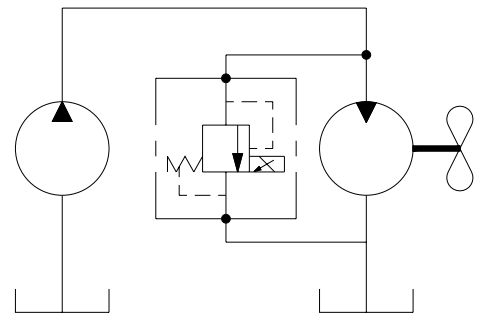
Cooling fan speed control

P103 040

**ELECTRICAL
 REQUIREMENTS**

All Sauer-Danfoss proportional cartridge valves are analog-type valves that control flow or pressure as a function of electric current. For this reason, proportional valves should be driven with a current-controlled device that will maintain constant output regardless of changes in system voltage, line losses, or temperature. Typically available current-controlled valve drivers output a pulse-width-modulated (PWM) square-wave signal. An advantage of a PWM signal is that the dither it provides significantly reduces hysteresis. Sauer-Danfoss recommends using a 100-200 Hz dither for best performance.

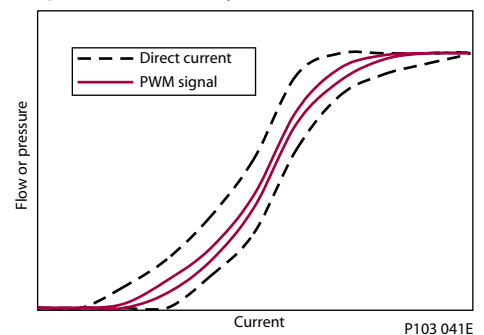
Proportional valve hysteresis

P103 041E

Typical performance

TERMS AND DEFINITIONS

Analog Proportional Valves are controlled by electric current, which may be direct current (DC) or a PWM signal.

Compensator is a hydraulic component that maintains a constant pressure drop across a fixed or variable orifice.

Current is the flow of electricity through a conductor or coil, normally measured in amps (A). Steady-state current flow in an electrical circuit can be calculated by Ohm's Law, as well as voltage and resistance.

$$\text{Ohm's Law} \quad I = \frac{V}{R}$$

Current Control is a feature of almost all valve drivers. The output of analog proportional valves is a direct function of current. If a valve is controlled with voltage, higher solenoid temperatures, which increase solenoid resistance, will result in lower valve output. To compensate for this, most valve drivers are designed with current feedback circuitry. This means that as solenoid temperature rises or as supply voltage and voltage losses change, the current and corresponding valve output are maintained.

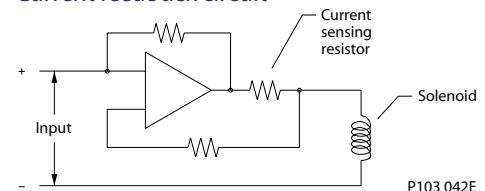
Current feedback circuit

Deadband is the range from zero to the minimum current which causes the valve to respond.

Digital Proportional Valves are extremely fast responding valves that are controlled by a precise on-off signal to produce an average output that is a function of duty cycle.

Dither is a "ripple" signal sent to a solenoid to reduce hysteresis. Dither can be a sine, square, or saw-tooth wave superimposed on a PWM signal or it can be a wave on top of a DC signal.

Duty Cycle is the % of time the valve is on divided by total time.

Hysteresis is the difference in output for a given input, depending on whether the input is increasing or decreasing. It is normally expressed as a % of the maximum rated output. For example, if a 160 l/min [42 US gal/min] proportional flow control valve provides 80 l/min [21 US gal/min] with 1 amp-increasing and 88 l/min [23 US gal/min] at 1 amp-decreasing, the hysteresis is:

$$\frac{(88-80)}{160} = 5\%$$

I_{\min} is the minimum current required for valve response (see deadband).

I_{\max} is the current required for maximum valve output.



Cartridge Valves Technical Information

Proportional valves

Application notes

**TERMS AND DEFINITIONS**
(continued)

PWM is an acronym for Pulse-Width-Modulation. Most valve drivers use a current-controlled PWM output to reduce valve hysteresis and to allow current control without excessive heat generation. A typical PWM output is a square wave from 80-500 Hz.

Ramping is the application of current to a solenoid with a linear or non-linear ramp, rather than an instantaneous step. Ramping current on and off to a proportional valve provides actuators with soft-starts and soft-stops. Ramps can generally be set or pre-programmed into valve drivers.

Resistance is a component's opposition to the flow of electrical current, usually measured in ohms (Ω). Resistance depends on the conductivity of the material, as well as size, shape, and temperature. Solenoid resistance can vary greatly with temperature; to compensate for this, current-controlled drivers are generally always used with proportional valves.

Threshold is the minimum current required for valve response; see deadband.

Valve Driver is a generic term for any device that sends a signal to a proportional valve. A valve driver may range from a simple electronic circuit attached to a knob or lever up to a microcontroller with custom software and multiple inputs and outputs.

Voltage is the potential for current to flow in an electric circuit, usually measured in volts (V).

Proportional valves
CP518-PNC

OPERATION

This valve is a non-compensated, normally-closed, proportional flow control.

SPECIFICATIONS

Specifications

Rated pressure	210 bar [3000 psi]
Rated flow at 6 bar [80 psi]	12 l/min [3 US gal/min]
Weight	0.36 kg [0.80 lb]
Hysteresis	10% maximum
Threshold current	0.8 A (12 VDC coil) 0.4 A (24 VDC coil)
Maximum control current	1.8 A (12 VDC coil) 0.9 A (24 VDC coil)
Pressure differential	21 bar [300 psi] maximum
Cavity	SDC08-2
Standard Coil	M19P 22 Watt
Coil nut	173802114

Theoretical performance

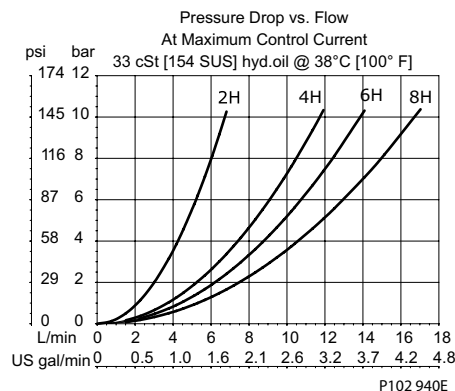
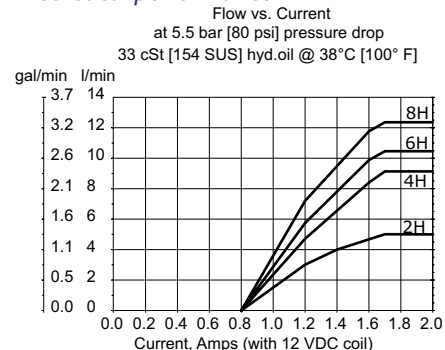

Schematic

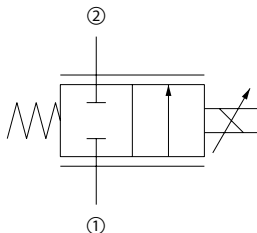

DIMENSIONS

mm [in]

Cross-sectional view

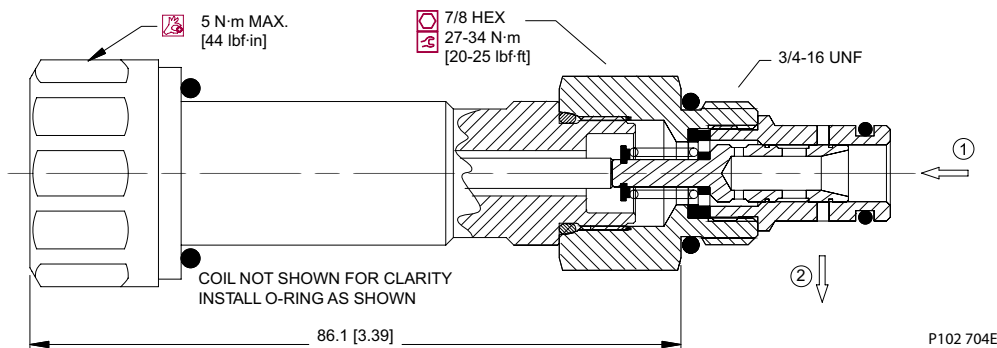

ORDERING INFORMATION

CP518-PNC-U-6S-2H-24-DE

Seals
U = Urethane
Seal kits 120591

Housing and ports
0 = Cartridge only
45 = AL, #4 SAE
65 = AL, #6 SAE
2B = AL, 1/4 BSP
3B = AL, 3/8 BSP

Housing P/N
No Housing CP08-2-4S
CP08-2-6S
SDC08-2-DG-2B
SDC08-2-DG-3B

Termination
00 = No connector
DE = Deutsch
DN = DIN 43650
FL = Lead wires

Voltage
00 = No coil
12 = 12 VDC
24 = 24 VDC

Flow code
2H = 5 l/min [1.3 US gal/min] at 5.5 bar [80 psi]
4H = 9 l/min [2.4 US gal/min]
6H = 11 l/min [2.9 US gal/min]
8H = 13 l/min [3.4 US gal/min]



Cartridge Valves Technical Information

Proportional valves

PSV10-NC



OPERATION

This is a normally-closed, direct-acting, spool-type, non-compensated, proportional flow control. Controlled flow is from port 1 to 2.

SPECIFICATIONS

Specifications

Rated pressure	260 bar [3770 psi]
Rated flow at 10 bar [145 psi]	40 l/min [11 US gal/min]
Leakage	420 cm ³ /min [25.6 in ³ /min] @ at rated pressure
Weight	0.51 kg [1.12 lb]
Hysteresis	5% maximum
Threshold current	0.4 A (12 VDC coil) 0.2 A (24 VDC coil)
Maximum control current	1.8 A (12 VDC coil) 0.9 A (24 VDC coil)
Pressure differential	0 bar [0 psi] maximum
Cavity	SDC10-2
Standard Coil	M19P 22 Watt

Theoretical performance

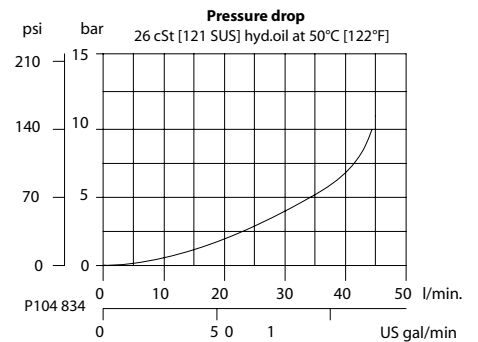
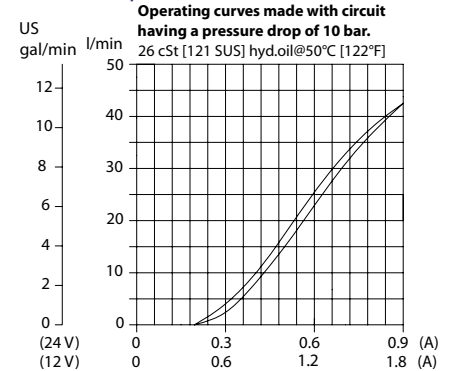

Schematic

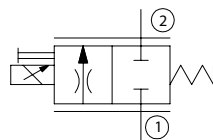

P104 832

DIMENSIONS

mm [in]

Cross-sectional view

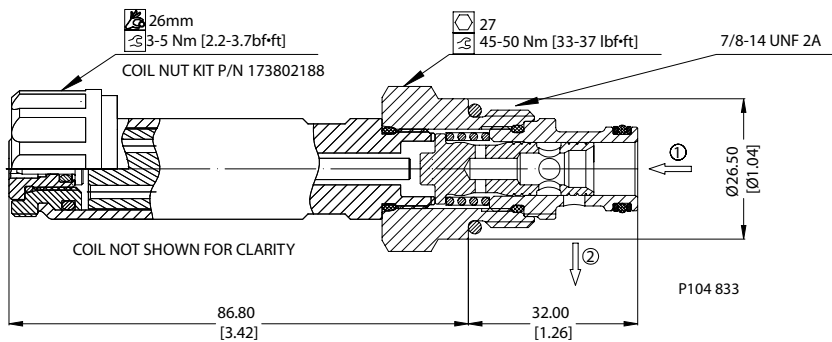

P104 833

ORDERING INFORMATION

PSV10-NC-40-12D-DN-B-00

Max regulated flow
40 = 40 l/min

Coil voltage
00 = No coil
12D = 12V DC
24D = 24V DC

Coil termination
00 = No coil
FL = Flying Lead
DN = ISO 4400 (DIN 43650)
DE = Deutsch

Body and Ports
00 = no housing
6S = Al, #6 SAE
8S = Al, #8 SAE
DG3B = Al, 3/8 BSP
DG4B = Al, 1/2 BSP
Other housing available

Seals Seal Kit
B = Buna-N seals 35400401
V = Viton seals 35400341

Body Nomenclature
No Body
CP10-2-6S
CP10-2-8S
SDC10-2-DG3B
SDC10-2-DG4B

P104 835

Proportional valves
PSV12-NC

OPERATION

This is a normally-closed, direct-acting, spool-type, non-compensated, proportional flow-control. Controlled flow is from port 1 to 2.

SPECIFICATIONS

Specifications

Rated pressure	260 bar [3770 psi]
Rated flow at 10 bar [145 psi]	80 l/min [21 US gal/min]
Leakage	420 cm ³ /min [25.6 in ³ /min] @ at rated pressure
Weight	0.76 kg [1.68 lb]
Hysteresis	5% maximum
Threshold current	0.5 A (12 VDC coil) 0.25 A (24 VDC coil)
Maximum control current	1.8 A (12 VDC coil) 0.9 A (24 VDC coil)
Pressure differential	0 bar [0 psi] maximum
Cavity	SDC12-2
Standard Coil	D14E(35W) 35 Watt

Theoretical performance

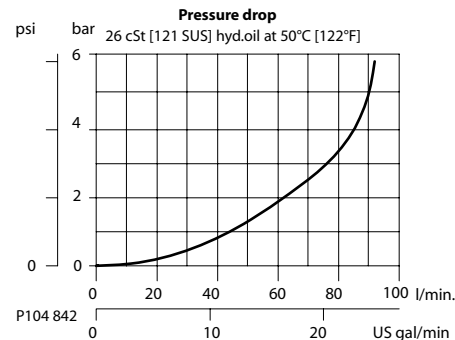
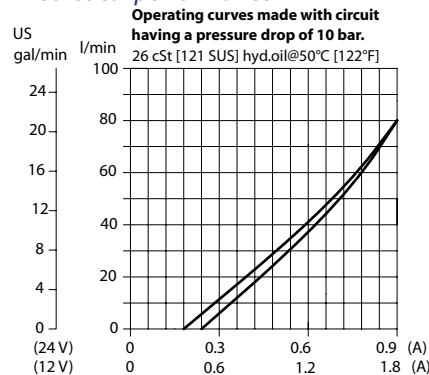

Schematic

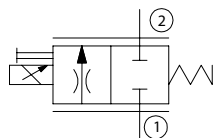

P104 832

DIMENSIONS

mm [in]

Cross-sectional view

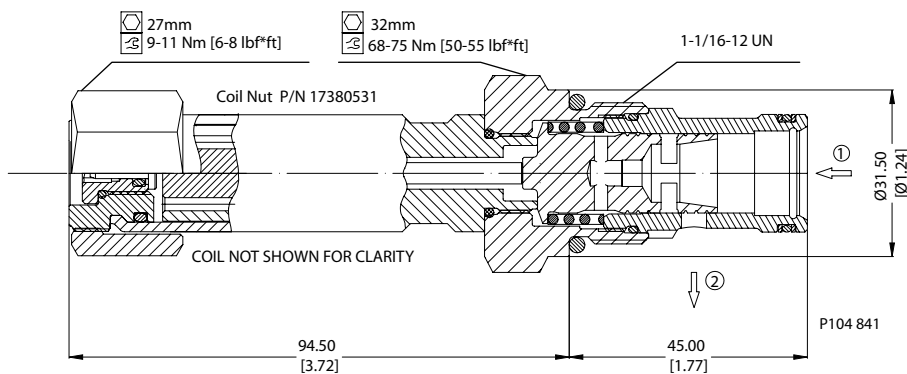

ORDERING INFORMATION

PSV12-NC-80-12D-DN-B-00

Max regulated flow
80 = 80 l/min

Coil voltage
00 = No coil
12D = 12V DC
24D = 24V DC

Coil termination
00 = No coil
FL = Flying Lead
DN = ISO 4400 (DIN 43650)
DE = Deutsch
AJ = Amp Junior
AS = Amp Superseal

Body and Ports
00 = No housing
10S = Al, #10 SAE
12S = Al, #12 SAE
DG4B = Al, 1/2 BSP
DG6B = Al, 3/4 BSP
Other housing available

Seals
B = Buna-N seals
V = Viton

Seal Kit
354008319
354008419

Body Nomencl.
No Body
CP12-2-10S
CP12-2-12S
SDC12-2-DG4B
SDC12-2-DG6B

P104 843



Cartridge Valves Technical Information

Proportional valves

PSV16-NC



OPERATION

This is a normally-closed, direct-acting, spool-type, non-compensated, proportional flow control. Controlled flow is from port 1 to 2.

SPECIFICATIONS

Specifications

Rated pressure	260 bar [3770 psi]
Rated flow at 10 bar [145 psi]	100 l/min [26 US gal/min]
Leakage	420 cm ³ /min [25.6 in ³ /min] @ at rated pressure
Weight	0.87 kg [1.92 lb]
Hysteresis	5% maximum
Threshold current	0.5 A (12 VDC coil) 0.25 A (24 VDC coil)
Maximum control current	1.8 A (12 VDC coil) 0.9 A (24 VDC coil)
Pressure differential	0 bar [0 psi] maximum
Cavity	SDC16-2
Standard Coil	D14E(35W) 35 Watt

Theoretical performance

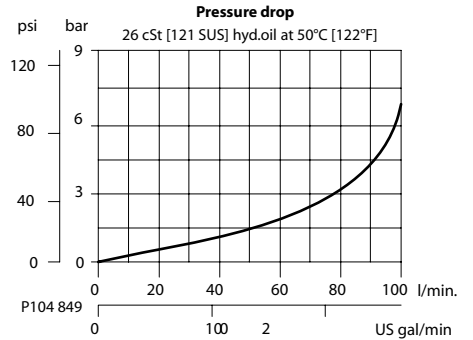
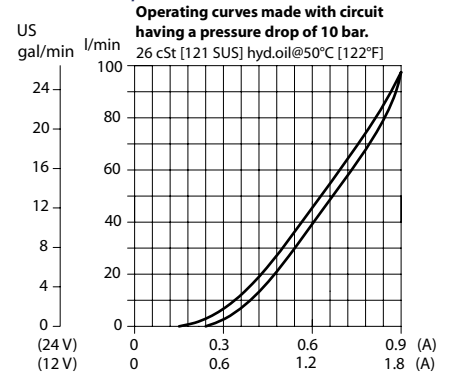

Schematic

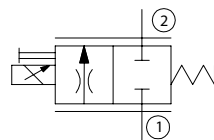

P104 832

DIMENSIONS

mm [in]

Cross-sectional view

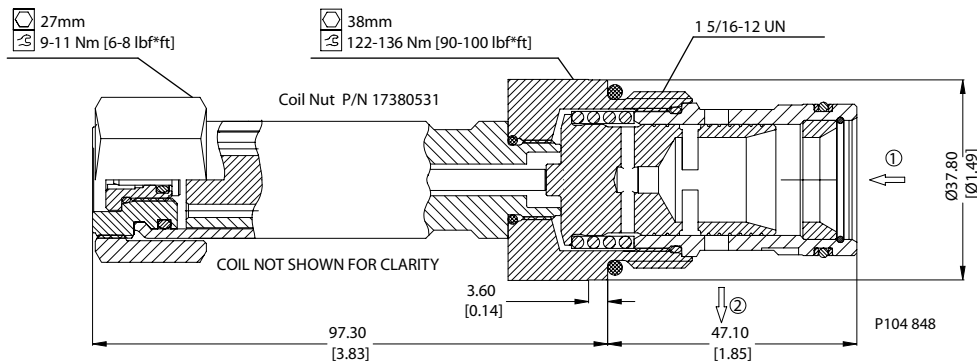

ORDERING INFORMATION

PSV16-NC-100-12D-DN-B-00

Max regulated flow
100 = 100 l/min

Coil voltage
00 = No coil
12D = 12V DC
24D = 24V DC

Coil termination
00 = No coil
FL = Flying Lead
DN = ISO 4400 (DIN 43650)
DE = Deutsch
AJ = Amp Junior
AS = Amp Superseal

Body and Ports

00 = No housing
DG6B = Al, 3/4 BSP
DG8B = Al, 1 BSP
12S = Al, #12 SAE
16S = Al, #16 SAE
Other housing available

Body Nomencl.

No Body
SDC16-2-DG-6B
SDC16-2-DG-8B
CP16-2-12S
CP16-2-16S

Seals

B = Buna-N seals
V = Viton

Seal Kit

354008719
354008819

P104 850

Proportional valves
 CP518-PNO

OPERATION

This valve is a non-compensated, normally-open, proportional flow control.

SPECIFICATIONS

Specifications

Rated pressure	210 bar [3000 psi]
Rated flow at 6 bar [80 psi]	12 l/min [3 US gal/min]
Weight	0.36 kg [0.80 lb]
Hysteresis	4% maximum
Threshold current	0.2 A (12 VDC coil) 0.1 A (24 VDC coil)
Maximum control current	1.2 A (12 VDC coil) 0.6 A (24 VDC coil)
Pressure differential	21 bar [300 psi] maximum
Cavity	SDC08-2
Standard Coil	M19P 22 Watt
Coil nut	173802114

Theoretical performance

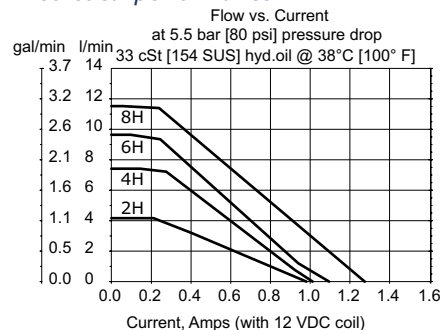

Schematic

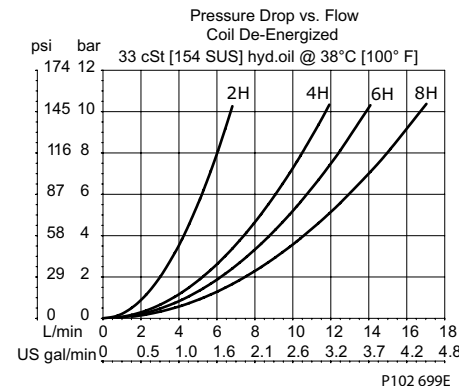
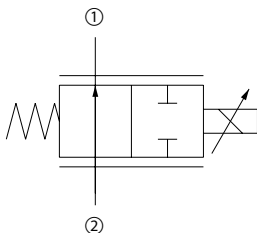

DIMENSIONS

mm [in]

Cross-sectional view

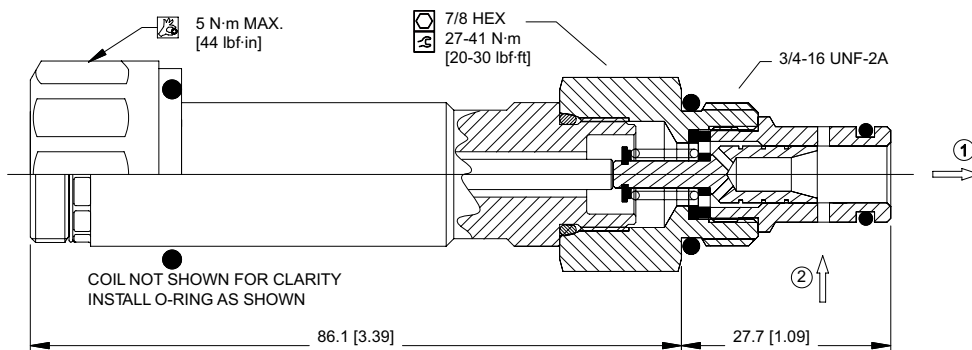

ORDERING INFORMATION

CP518-PNO-U-6S-2H-24-DE

Seals
 U = Urethane Seal kits 120591

Housing and ports
 0 = Cartridge only
 4S = AL, #4 SAE
 6S = AL, #6 SAE
 2B = AL, 1/4 BSP
 3B = AL, 3/8 BSP

Housing P/N
 No Housing CP08-2-4S
 CP08-2-6S
 SDC08-2-DG-2B
 SDC08-2-DG-3B

Termination
 00 = No connector
 DE = Deutsch
 DN = DIN 43650
 FL = Lead wires

Voltage
 00 = No coil
 12 = 12 VDC
 24 = 24 VDC

Flow code
 2H = 4 l/min [1.0 US gal/min] at 5.5 bar [80 psi]



Cartridge Valves Technical Information

Proportional valves

PSV10-NO



OPERATION

This is a normally-open, direct-acting, spool-type, non-compensated, proportional flow-control. Controlled flow is from port 1 to 2.

SPECIFICATIONS

Specifications

Rated pressure	260 bar [3770 psi]
Rated flow at 10 bar [145 psi]	45 l/min [12 US gal/min]
Leakage	420 cm ³ /min [25.6 in ³ /min] @ at rated pressure
Weight	0.51 kg [1.12 lb]
Hysteresis	5% maximum
Threshold current	0.1 A (12 VDC coil) 0.05 A (24 VDC coil)
Maximum control current	1.8 A (12 VDC coil) 0.9 A (24 VDC coil)
Pressure differential	0 bar [0 psi] maximum
Cavity	SDC10-2
Standard Coil	M19P 22 Watt

Theoretical performance

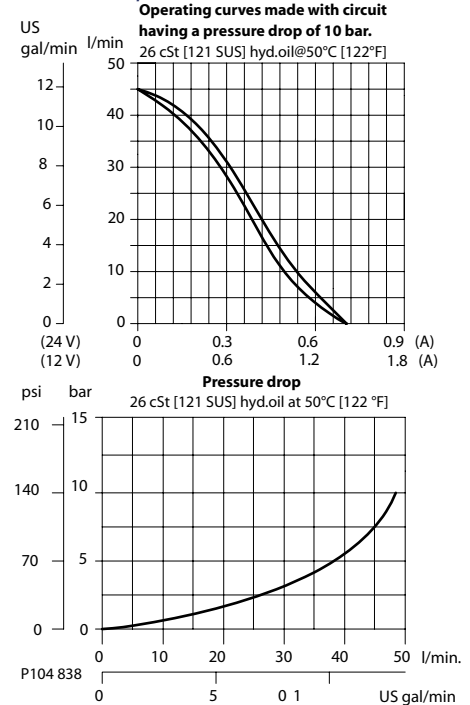

Proportional valves PSV10-NO

Schematic

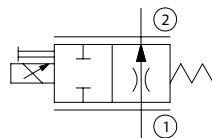

P104 836

DIMENSIONS

mm [in]

Cross-sectional view

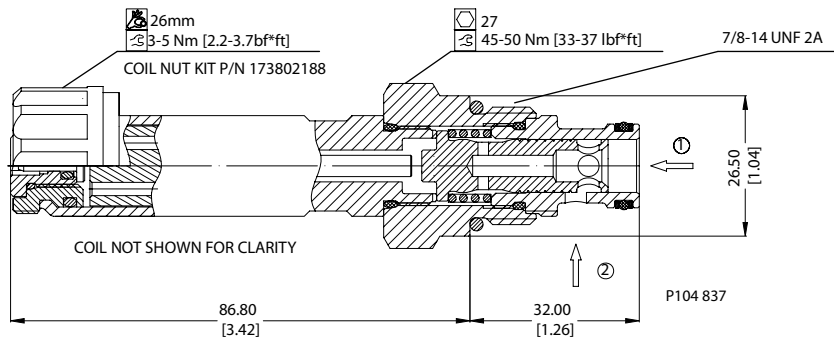

P104 837

ORDERING INFORMATION

PSV10-NO-45-12D-DN-B-00

Max regulated flow
45 = 45 l/min

Coil voltage
00 = No coil
12D = 12V DC
24D = 24V DC

Coil termination
00 = No coil
FL = Flying Lead
DN = ISO 4400 (DIN 43650)
DE = Deutsch

Body and Ports
Omit = Cartridge only
6S = Al #6 SAE
8S = Al, #8 SAE
DG3B = Al, 3/8 BSP
DG4B = Al, 1/2 BSP
Hother housing available

Seals
B = Buna-N seals
V = Viton seals

Seal Kit
35400401
35400341

Body Nomenclature
No Body
CP10-2-6S
CP10-2-8S
SDC10-2-DG3B
SDC10-2-DG4B

P104 839

Proportional valves
PSV12-NO

OPERATION

This is a normally-open, direct-acting, spool-type, non-compensated, proportional flow-control. Controlled flow is from port 1 to 2.

SPECIFICATIONS

Specifications

Rated pressure	260 bar [3770 psi]
Rated flow at 10 bar [145 psi]	100 l/min [26 US gal/min]
Leakage @ at rated pressure	420 cm ³ /min [25.6 in ³ /min]
Weight	0.76 kg [1.68 lb]
Hysteresis	5% maximum
Threshold current	0.3 A (12 VDC coil) 0.15 A (24 VDC coil)
Maximum control current	1.8 A (12 VDC coil) 0.9 A (24 VDC coil)
Pressure differential	0 bar [0 psi] maximum
Cavity	SDC12-2
Standard Coil	D14E(35W) 35 Watt

Theoretical performance

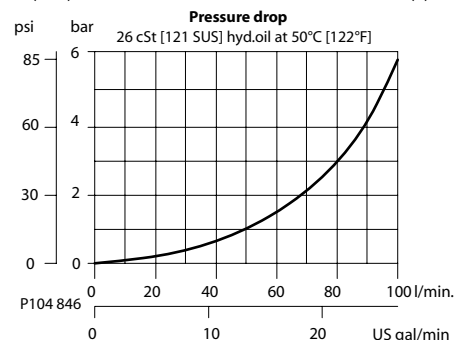
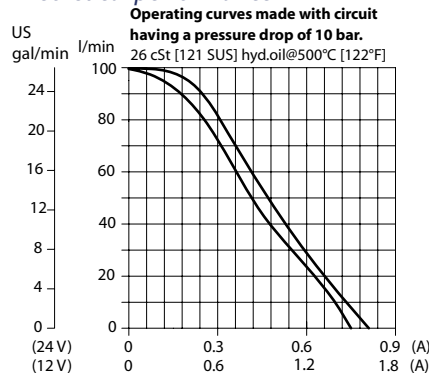

Schematic

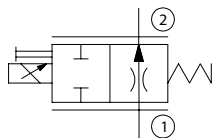

P104 836

DIMENSIONS

mm [in]

Cross-sectional view

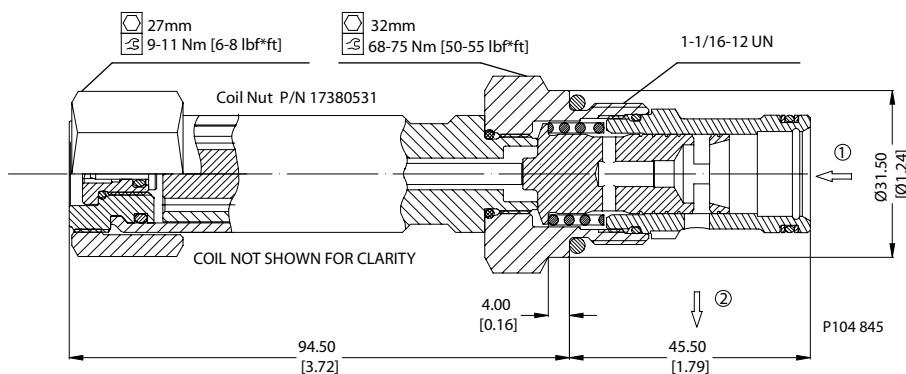

ORDERING INFORMATION

PSV12-NO-100-12D-DN-B-00

Max regulated flow
 100 = 100 l/min

Coil voltage
 00 = No coil
 12D = 12V DC
 24D = 24V DC

Coil termination
 00 = No coil
 FL = Flying Lead
 DN = ISO 4400 (DIN 43650)
 DE = Deutsch
 AJ = Amp Junior
 AS = Amp superseal

Body and Ports
 00 = No housing
 10S = Al, #10 SAE
 12S = Al, #12 SAE
 DG4B = Al, 1/2 BSP
 DG6B = Al, 3/4 BSP
 Other housing available

Seals Seal Kit
 B = Buna-N seals 354008319
 V = Viton 354008419

Body Nomencl.
 No Body
 CP12-2-10S
 CP12-2-12S
 SDC12-2-DG4B
 SDC12-2-DG6B

P104 847



Cartridge Valves Technical Information

Proportional valves

PSV16-NO



OPERATION

This is a normally-open, direct-acting, spool-type, non-compensated, proportional flow-control. Controlled flow is from port 1 to 2.

SPECIFICATIONS

Specifications

Rated pressure	260 bar [3770 psi]
Rated flow at 10 bar [145 psi]	110 l/min [29 US gal/min]
Leakage	420 cm ³ /min [25.6 in ³ /min] @ at rated pressure
Weight	0.87 kg [1.92 lb]
Hysteresis	5% maximum
Threshold current	0.3 A (12 VDC coil) 0.15 A (24 VDC coil)
Maximum control current	1.8 A (12 VDC coil) 0.9 A (24 VDC coil)
Pressure differential	0 bar [0 psi] maximum
Cavity	SDC16-2
Standard Coil	D14E(35W) 35 Watt

Theoretical performance

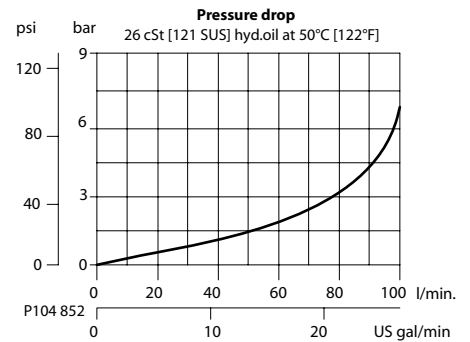
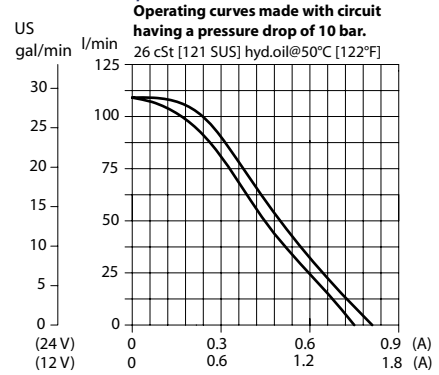

Schematic

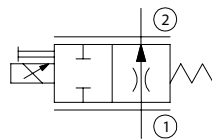

P104 836

DIMENSIONS

mm [in]

Cross-sectional view

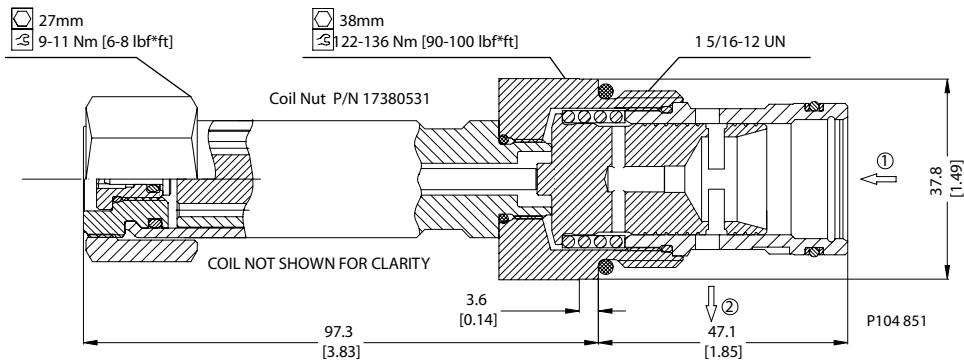

ORDERING INFORMATION

PSV16-NO-110-12D-DN-B-00

Max regulated flow
110 = 110 l/min

Coil voltage
00 = No coil
12D = 12V DC
24D = 24V DC

Coil termination
00 = No coil
FL = Flying Lead
DN = ISO 4400 (DIN 43650)
DE = Deutsch
AJ = Amp Junior
AS = Amp Superseal

Body and Ports
00 = No housing
DG6B = Al, 3/4 BSP
DG8B = Al, 1 BSP
12S = Al, #12 SAE
16S = Al, #16 SAE
Other housing available

Seals
B = Buna-N seals
V = Viton

Seal Kit
354008719
354008819

Body Nomencl.
No Body
SDC16-2-DG-6B
SDC16-2-DG-8B
CP16-2-12S
CP16-2-16S

P104 853

Proportional valves
 PSVP10-NCR

OPERATION

This is a non-compensated, normally-closed, pilot-operated, poppet-type, proportional flow-control. Controlled flow is from port 1 to 2.

SPECIFICATIONS

Specifications

Rated pressure	260 bar [3770 psi]
Rated flow at 260 bar [3771 psi]	55 l/min [14 US gal/min]
Leakage	6 drops/min @ at rated pressure
Weight	0.54 kg [1.19 lb]
Hysteresis	8% maximum
Threshold current	0.8 A (12 VDC coil) 0.4 A (24 VDC coil)
Maximum control current	1.8 A (12 VDC coil) 0.9 A (24 VDC coil)
Pressure differential	0 bar [0 psi] maximum
Cavity	SDC10-2
Standard Coil	M19P 22 Watt

Theoretical performance

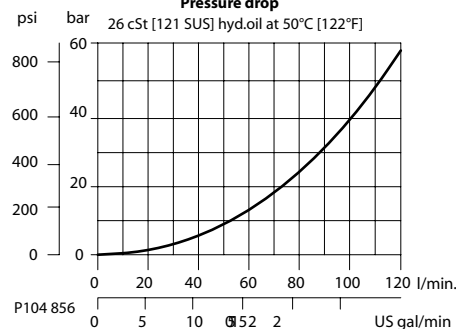
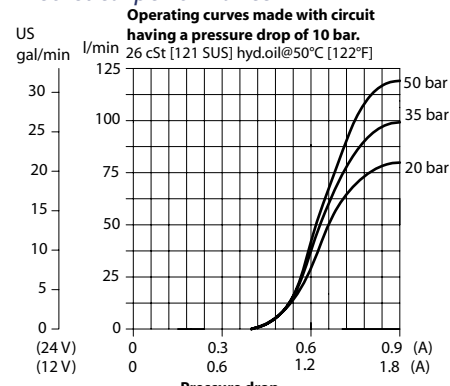

Schematic

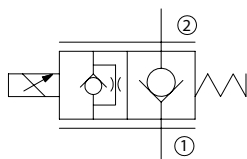

P104 854

DIMENSIONS

mm [in]

Cross-sectional view

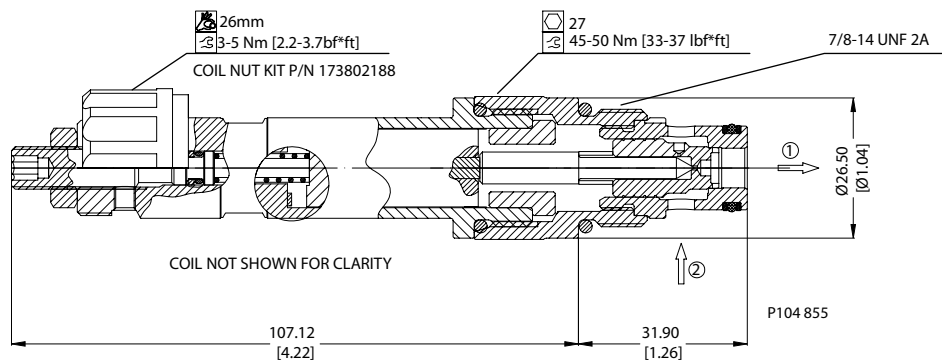

ORDERING INFORMATION

PSVP10-NCR-12D-DN-B-00

- Coil voltage**
 00 = No coil
 12D = 12V DC
 24D = 24V DC
- Coil termination**
 00 = No coil
 FL = Flying Lead
 DN = ISO 4400 (DIN 43650)
 DE = Deutsch

- Body and Ports**
 00 = No housing
 6S = Al, #6 SAE
 8S = Al, #8 SAE
 DG3B = Al, 3/8 BSP
 DG4B = Al, 1/2 BSP
 Other housing available

- Seals**
 B = Buna-N seals
 V = Viton seals
- Seal Kit**
 35400401
 35400341

- Body Nomenclature**
 No Body
 CP10-2-6S
 CP10-2-8S
 SDC10-2-DG3B
 SDC10-2-DG4B

P104 857



Cartridge Valves Technical Information

Proportional valves

PSVP12-NCR



OPERATION

This is a non-compensated, normally-closed, pilot-operated, poppet-type, proportional flow-control. Controlled flow is from port 1 to 2.

SPECIFICATIONS

Specifications

Rated pressure	260 bar [3770 psi]
Rated flow at 260 bar [3771 psi]	70 l/min [18 US gal/min]
Leakage	6 drops/min @ at rated pressure
Weight	0.60 kg [1.32 lb]
Hysteresis	8% maximum
Pressure differential	0 bar [0 psi] maximum
Cavity	SDC12-2
Standard Coil	M19P 22 Watt

Theoretical performance

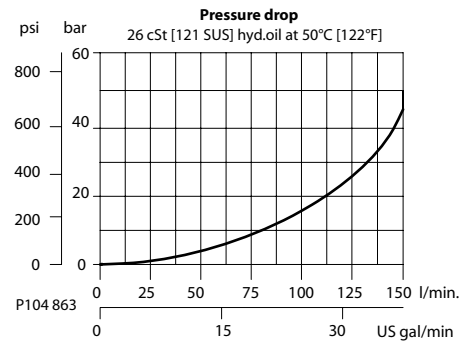
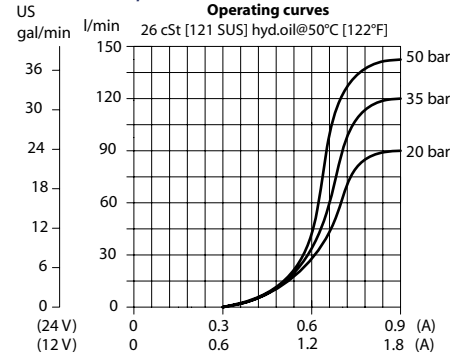

Schematic

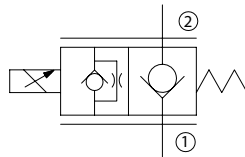

P104 854

DIMENSIONS

mm [in]

Cross-sectional view

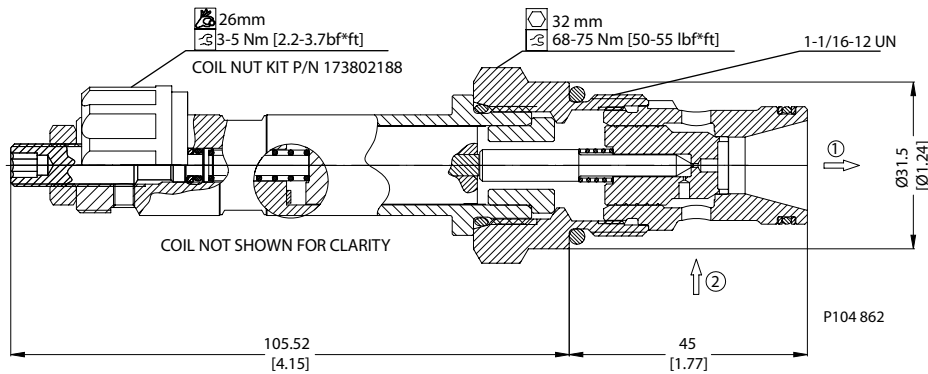

P104 862

ORDERING INFORMATION

PSVP12-NCR-12D-DN-B-00

- Coil voltage**
 00 = No coil
 12D = 12V DC
 24D = 24V DC
- Coil termination**
 00 = No coil
 FL = Flying Lead
 DN = ISO 4400 (DIN 43650)
 DE = Deutsch

- Body and Ports**
 00 = No housing
 10S = Al, #10 SAE
 12S = Al, #12 SAE
 4B = Al, 1/2 BSP
 6B = Al, 3/4 BSP
 Other housing available

- Body Nomencl.**
 No Body
 CP12-3-10S
 CP12-3-12S
 CP12-3-4B
 CP12-3-6B

- Seals**
 B = Buna-N seals
 V = Viton
- Seal Kit**
 354008319
 354008419
- P104 864

Proportional valves
 PSVP16-NCR

OPERATION

This is a non-compensated, normally-closed, pilot-operated, poppet-type, proportional flow-control. Controlled flow is from port 1 to 2.

SPECIFICATIONS

Specifications

Rated pressure	260 bar [3770 psi]
Rated flow at 260 bar [3771 psi]	90 l/min [24 US gal/min]
Leakage	6 drops/min @ at rated pressure
Weight	0.85 kg [1.87 lb]
Hysteresis	8% maximum
Pressure differential	0 bar [0 psi] maximum
Cavity	SDC16-2
Standard Coil	M19P 22 Watt

Theoretical performance

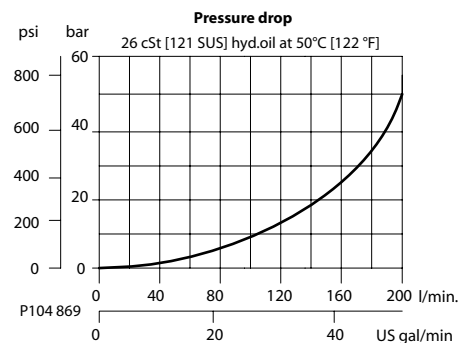
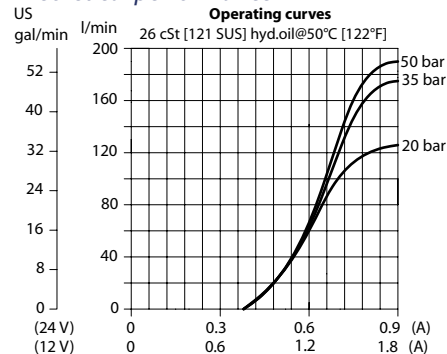

Schematic

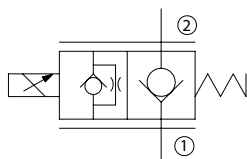

P104 854

DIMENSIONS

mm [in]

Cross-sectional view

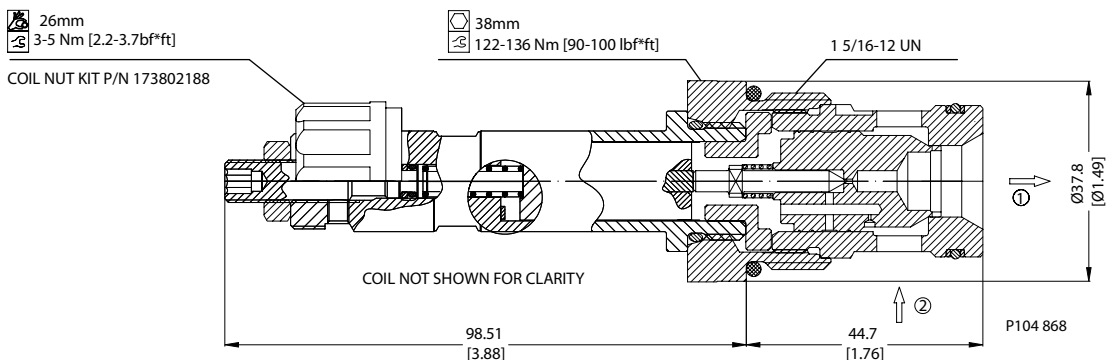

ORDERING INFORMATION

PSVP16-NCR-12D-DN-B-00

Coil voltage

- 00 = No coil
- 12D = 12V DC
- 24D = 24V DC

Coil termination

- 00 = No coil
- FL = Flying Lead
- DN = ISO 4400 (DIN 43650)
- DE = Deutsch

Body and Ports

- 00 = No housing
- DG6B = Al, 3/4 BSP
- DG8B = Al, 1 BSP
- 12S = Al, #12 SAE
- 16S = Al, #16 SAE
- Other housing available

Seals

- B = Buna-N seals
- V = Viton

Seal Kit

- 354008719
- 354008819

Body Nomencl.

- No Body
- SDC16-2-DG-6B
- SDC16-2-DG-8B
- CP16-2-12S
- CP16-2-16S

P104 870



Cartridge Valves Technical Information

Proportional valves

PSVP10-NOR



OPERATION

This is a non-compensated, normally-open, pilot-operated, poppet-type, proportional flow-control. Controlled flow is from port 1 to 2.

SPECIFICATIONS

Specifications

Rated pressure	260 bar [3770 psi]
Rated flow at 260 bar [3771 psi]	45 l/min [12 US gal/min]
Leakage	6 drops/min @ at rated pressure
Weight	0.54 kg [1.19 lb]
Hysteresis	8% maximum
Pressure differential	0 bar [0 psi] maximum
Cavity	SDC10-2
Standard Coil	M19P 22 Watt

Theoretical performance

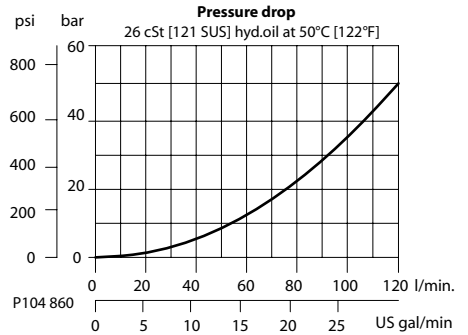
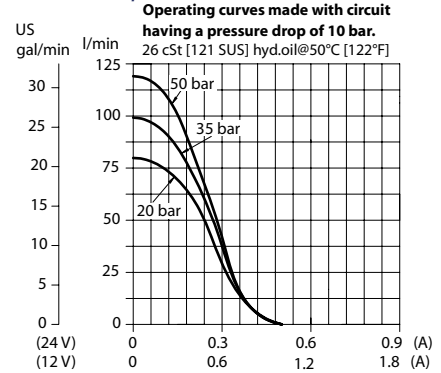

Schematic

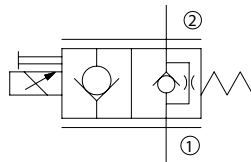

P104 858

DIMENSIONS

mm [in]

Cross-sectional view

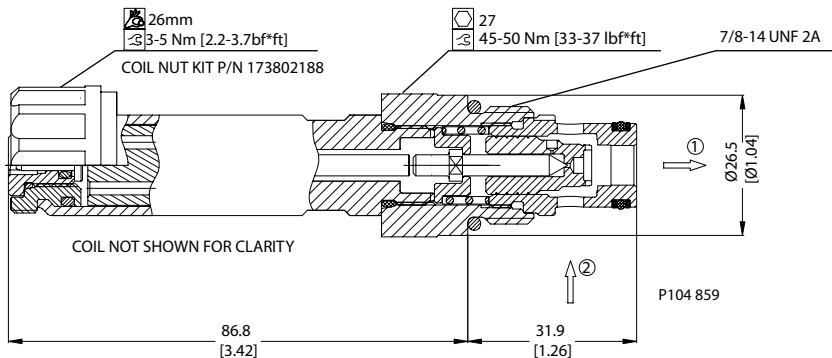

ORDERING INFORMATION

PSVP10-NOR-12D-DN-B-00

Coil voltage
00 = No coil
12D = 12V DC
24D = 24V DC

Coil termination
00 = No coil
FL = Flying Lead
DN = ISO 4400 (DIN 43650)
DE = Deutsch

Body and Ports
00 = No housing
6S = Al, #6 SAE
8S = Al, #8 SAE
DG3B = Al, 3/8 BSP
DG4B = Al, 1/2 BSP
Other housing available

Body Nomenclature
No Body
CP10-2-6S
CP10-2-8S
SDC10-2-DG3B
SDC10-2-DG4B

Seals
B = Buna-N seals
V = Viton seals

Seal Kit
35400401
35400341

P104 861



Cartridge Valves Technical Information

Proportional valves

PSVP12-NOR



Proportional valves
PSVP12-NOR

OPERATION

This is a non-compensated, normally-open, pilot-operated, poppet-type, proportional flow-control. Controlled flow is from port 1 to 2.

SPECIFICATIONS

Specifications

Rated pressure	260 bar [3770 psi]
Rated flow at 260 bar [3771 psi]	70 l/min [18 US gal/min]
Leakage	6 drops/min @ at rated pressure
Weight	0.60 kg [1.32 lb]
Hysteresis	8% maximum
Pressure differential	0 bar [0 psi] maximum
Cavity	SDC12-2
Standard Coil	M19P 22 Watt

Theoretical performance

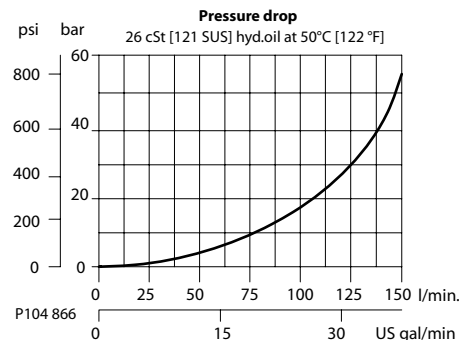
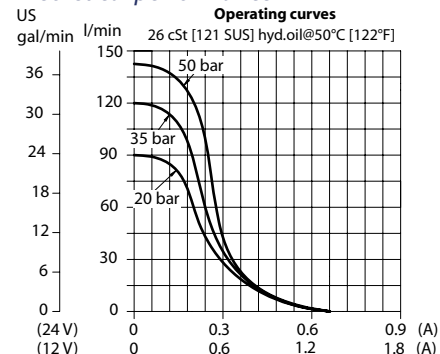

Schematic

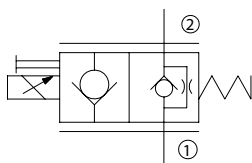

P104 858

DIMENSIONS

mm [in]

Cross-sectional view

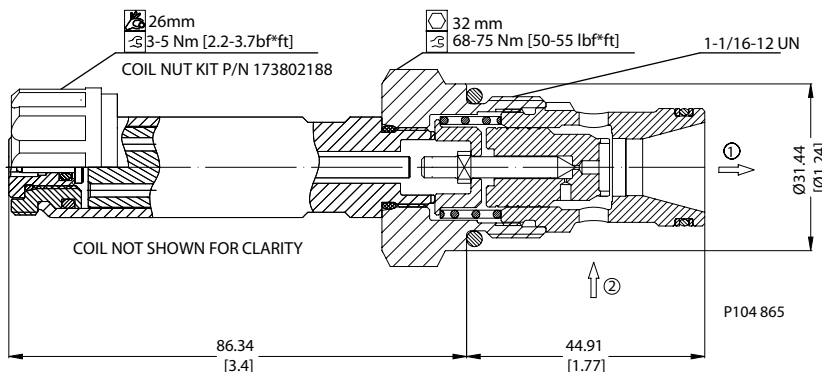

ORDERING INFORMATION

PSVP12-NOR-12D-DN-B-00

Coil voltage
00 = No coil
12D = 12V DC
24D = 24V DC

Coil termination
00 = No coil
FL = Flying Lead
DN = ISO 4400 (DIN 43650)
DE = Deutsch

Body and Ports
00 = No housing
10S = Al, #10 SAE
12S = Al, #12 SAE
4B = Al, 1/2 BSP
6B = Al, 3/4 BSP
Other housing available

Seals
B = Buna-N seals
V = Viton

Seal Kit
354008319
354008419

Body Nomencl.
No Body
CP12-3-10S
CP12-3-12S
CP12-3-4B
CP12-3-6B

P104 867



Cartridge Valves Technical Information

Proportional valves

PSVP16-NOR



OPERATION

This is a non-compensated, normally-open, pilot-operated, poppet-type, proportional flow-control. Controlled flow is from port 1 to 2.

SPECIFICATIONS

Specifications

Rated pressure	260 bar [3770 psi]
Rated flow at 260 bar [3771 psi]	80 l/min [21 US gal/min]
Leakage	6 drops/min @ at rated pressure
Weight	0.85 kg [1.87 lb]
Hysteresis	8% maximum
Pressure differential	0 bar [0 psi] maximum
Cavity	SDC16-2
Standard Coil	M19P 22 Watt

Theoretical performance

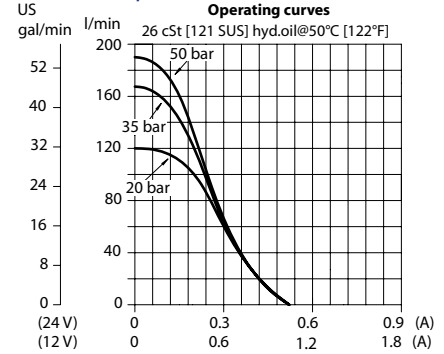

Schematic

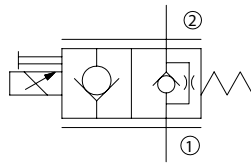

P104 858

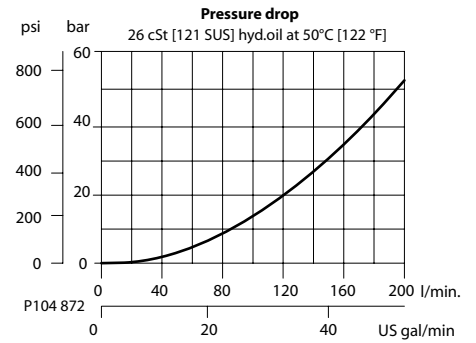

DIMENSIONS

mm [in]

Cross-sectional view

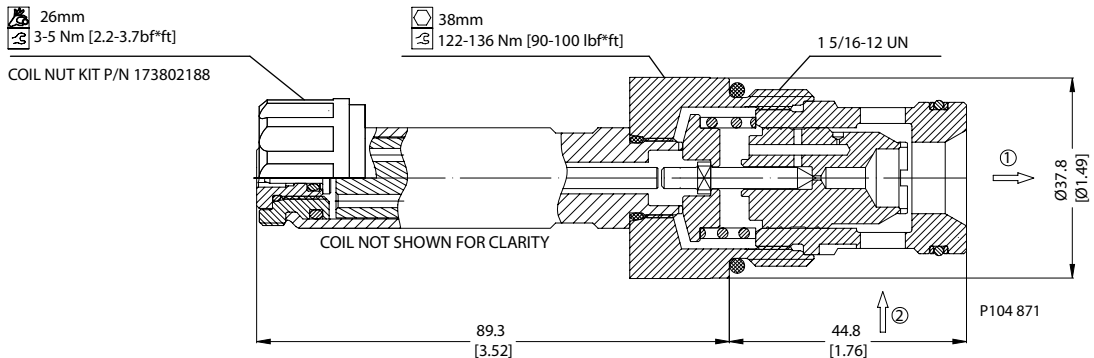

ORDERING INFORMATION

PSVP16-NOR-12D-DN-B-00

Coil voltage
 00 = No coil
 12D = 12V DC
 24D = 24V DC

Coil termination
 00 = No coil
 FL = Flying Lead
 DN = ISO 4400 (DIN 43650)
 DE = Deutsch

Body and Ports
 00 = No housing
 DG6B = Al, 3/4 BSP
 DG8B = Al, 1 BSP
 12S = Al, #12 SAE
 16S = Al, #16 SAE
 Hother housing available

Body Nomencl.
 No Body
 SDC16-2-DG-6B
 SDC16-2-DG-8B
 CP16-2-12S
 CP16-2-16S

Seals
 B = Buna-N seals
 V = Viton

Seal Kit
 354008719
 354008819

P104 873

Proportional valves
PFC10-PC

OPERATION

This is a pressure-compensated, priority-type, normally-closed, spool-type, proportional flow-control. Controlled flow is from port 1 to 3, port 2 is bypass.

SPECIFICATIONS

Specifications

Rated pressure	260 bar [3770 psi]
Rated flow at 260 bar [3771 psi]	40 l/min [11 US gal/min]
Leakage @ at rated pressure	420 cm ³ /min [25.6 in ³ /min]
Weight	0.62 kg [1.37 lb]
Hysteresis	8% maximum
Threshold current	0.36 A (12 VDC coil) 0.18 A (24 VDC coil)
Maximum control current	1.8 A (12 VDC coil) 0.9 A (24 VDC coil)
Pressure differential	0 bar [0 psi] maximum
Cavity	SDC10-3
Standard Coil	M19P 22 Watt

Theoretical performance

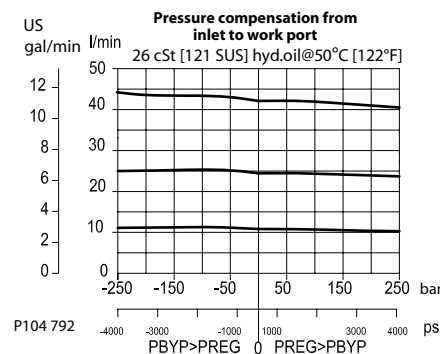
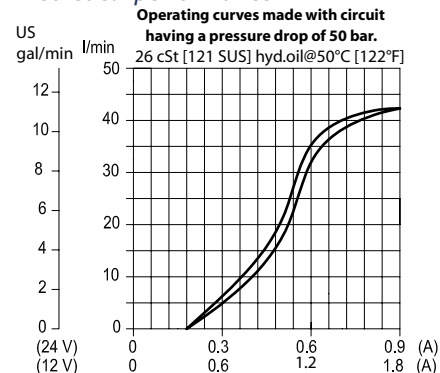

Schematic

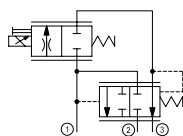

P104 789

DIMENSIONS

mm [in]

Cross-sectional view

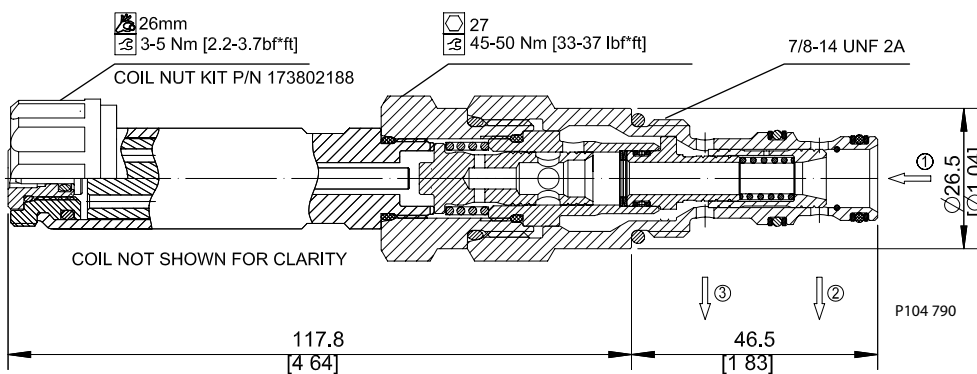

ORDERING INFORMATION

PFC10-PC-40-12D-DN-B-00

Max regulated flow
40 = 40 l/min

Coil voltage
00 = No coil
12D = 12V DC
24D = 24V DC

Coil termination:
00 = No coil
FL = Flying Lead
DN = DIN 43650
DE = Deutsch

Body and ports
00 = No housing
6S = Al, #6 SAE
8S = Al, #8 SAE
SE3B = Al, 3/8" BSP
SE4B = Al, 1/2" BSP

Other housing available
Seals kit
B = Buna-N 354004210
V = Viton 354003719

Body Nomenclature
No Body
CP10-3-6S
CP10-3-8S
SDC10-3-SE3B
SDC10-3-SE4B

P104 791



Cartridge Valves Technical Information

Proportional valves

PFC12-PC



OPERATION

This is a pressure-compensated, priority-type, normally-closed, spool-type, proportional flow-control. Controlled flow is from port 1 to 3, port 2 is bypass.

SPECIFICATIONS

Specifications

Rated pressure	260 bar [3770 psi]
Rated flow at 260 bar [3771 psi]	65 l/min [17 US gal/min]
Leakage	420 cm ³ /min [25.6 in ³ /min] @ at rated pressure
Weight	0.81 kg [1.79 lb]
Hysteresis	8% maximum
Threshold current	0.5 A (12 VDC coil) 0.25 A (24 VDC coil)
Maximum control current	1.8 A (12 VDC coil) 0.9 A (24 VDC coil)
Pressure differential	0 bar [0 psi] maximum
Cavity	SDC12-3
Standard Coil	D14E(35W) 35 Watt

Theoretical performance

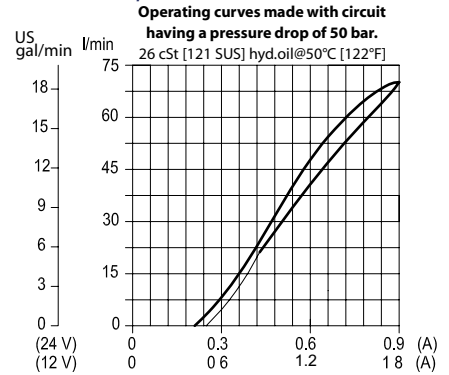

Schematic

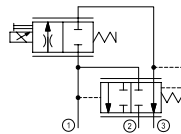

P104 789

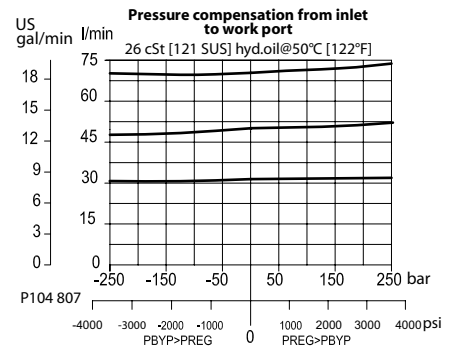

P104 807

DIMENSIONS

mm [in]

Cross-sectional view

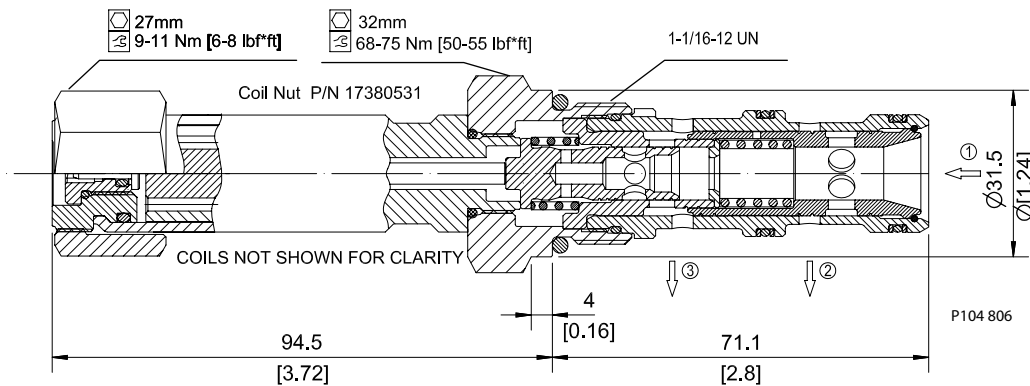

ORDERING INFORMATION

PFC12-PC-65-12D-DN-B-00

Max regulated flow
65 = 65 l/min

Coil voltage
00 = No coil
12D = 12V DC
24D = 24V DC

Coil termination
00 = No coil
FL = Flying Lead
DN = ISO 4400 (DIN 43650)
DE = Deutsch
AJ = Amp Junior
AS = Amp Superseal

Body and Ports
00 = No housing
10S = Al, #10 SAE
12S = Al, #12 SAE
4B = Al, 1/2 BSP
6B = Al, 3/4 BSP
Other housing available

Seals
B = Buna-N seals
V = Viton

Seal Kit
354008319
354008419

Body Nomencl.
No Body
CP12-3-10S
CP12-3-12S
CP12-3-4B
CP12-3-6B

P104 808

Proportional valves
PFC16-PC

OPERATION

This is a pressure-compensated, priority-type, normally-closed, spool-type, proportional flow-control. Controlled flow is from port 1 to 3, port 2 is bypass.

SPECIFICATIONS

Specifications

Rated pressure	260 bar [3770 psi]
Rated flow at 260 bar [3771 psi]	85 l/min [22 US gal/min]
Leakage @ at rated pressure	420 cm ³ /min [25.6 in ³ /min]
Weight	0.97 kg [2.14 lb]
Hysteresis	8% maximum
Threshold current	0.4 A (12 VDC coil) 0.2 A (24 VDC coil)
Maximum control current	1.8 A (12 VDC coil) 0.9 A (24 VDC coil)
Pressure differential	0 bar [0 psi] maximum
Cavity	SDC16-3
Standard Coil	D14E(35W) 35 Watt

Theoretical performance

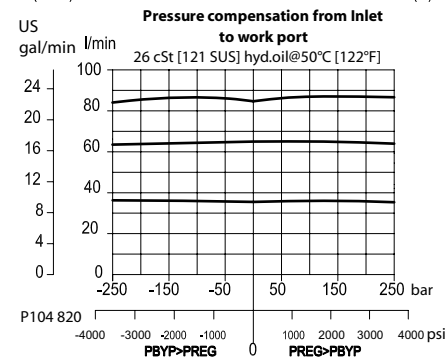
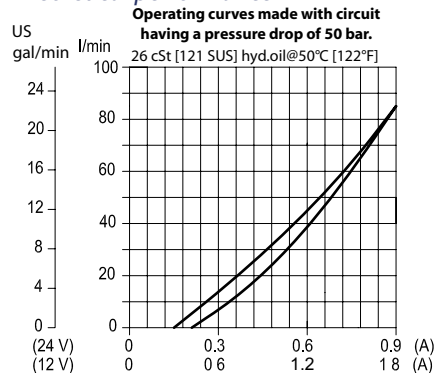

Schematic

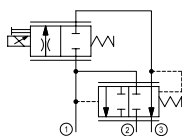

P104 789

DIMENSIONS

mm [in]

Cross-sectional view

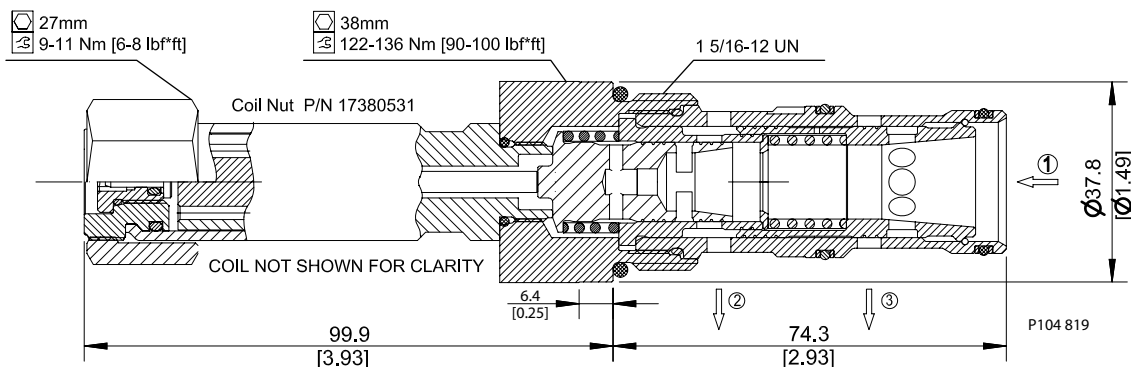

P104 819

ORDERING INFORMATION

PFC16-PC-85-12D-DN-B-00

Max regulated flow
85 = 85 l/min

Coil voltage
 00 = No coil
 12D = 12V DC
 24D = 24V DC

Coil termination
 00 = No coil
 FL = Flying Lead
 DN = ISO 4400 (DIN 43650)
 DE = Deutsch
 AJ = Amp Junior
 AS = Amp Superseal

Body and Ports
 00 = No housing
 6B = Al, 3/4 BSP
 8B = Al, 1 BSP
 12S = Al, #12 SAE
 16S = Al, #16 SAE
 Other housings available

Seals **Seal Kit**
 B = Buna-N seals 354008919
 V = Viton seals 354009019

Body Nomenclature
 No housing
 SDC16-3-HE-6B
 SDC16-3-HE-8B
 CP16-3-12S
 CP16-3-16S

P104 821



Cartridge Valves Technical Information

Proportional valves PFC10-PO



OPERATION

This is a pressure-compensated, priority-type, normally-open, spool-type, proportional flow-control. Controlled flow is from port 1 to 3, port 2 is bypass.

SPECIFICATIONS

Specifications

Rated pressure	260 bar [3770 psi]
Rated flow at 260 bar [3771 psi]	35 l/min [9 US gal/min]
Leakage	420 cm ³ /min [25.6 in ³ /min] @ at rated pressure
Weight	0.72 kg [1.59 lb]
Hysteresis	8% maximum
Threshold current	0.1 A (12 VDC coil) 0.05 A (24 VDC coil)
Maximum control current	1.8 A (12 VDC coil) 0.9 A (24 VDC coil)
Pressure differential	0 bar [0 psi] maximum
Cavity	SDC10-3
Standard Coil	M19P 22 Watt

Theoretical performance

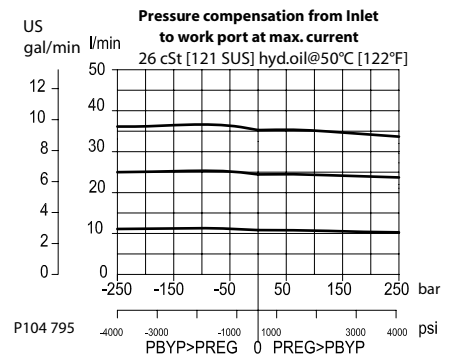
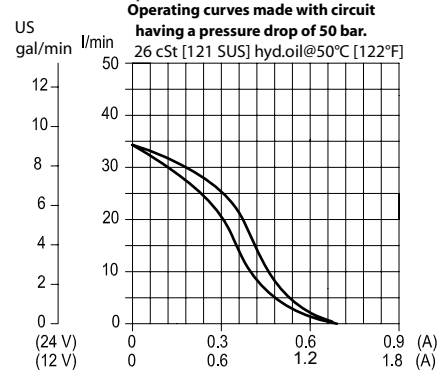

Schematic

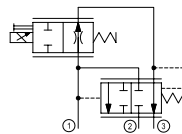

P104 793

DIMENSIONS

mm [in]

Cross-sectional view

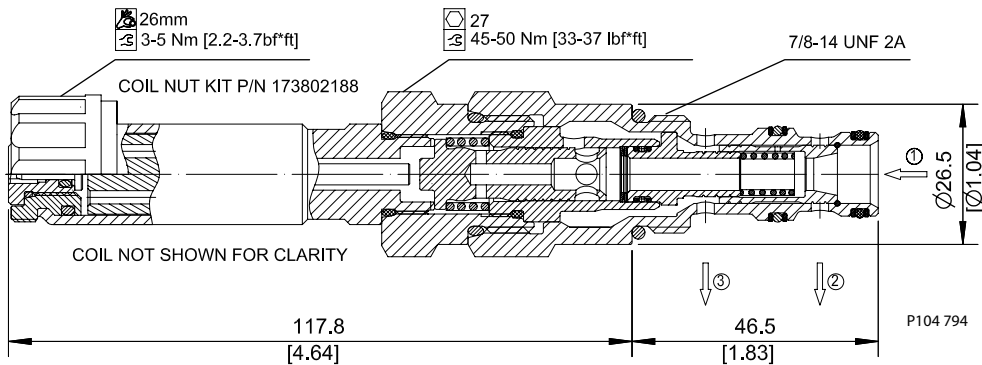

ORDERING INFORMATION

PFC10-PO-35-12D-DN-B-00

Max regulated flow
35 = 35 l/min

Coil voltage
00 = No coil
12D = 12V DC
24D = 24V DC

Coil termination:
00 = No coil
FL = Flying Lead
DN = DIN 43650
DE = Deutsch

Body and ports
00 = No housing
6S = Al, #6 SAE
8S = Al, #8 SAE
SE3B = Al, 3/8" BSP
SE4B = Al, 1/2" BSP
Other housing available

Seals kit
B = Buna-N 354004210
V = Viton 354003719

Body Nomenclature
No Body
CP10-3-6S
CP10-3-8S
SDC10-3-SE3B
SDC10-3-SE4B

P104 796

Proportional valves
PFC12-PO

OPERATION

This is a pressure-compensated, priority-type, normally-open, spool-type, proportional flow-control. Controlled flow is from port 1 to 3, port 2 is bypass.

SPECIFICATIONS

Specifications

Rated pressure	260 bar [3770 psi]
Rated flow at 260 bar [3771 psi]	70 l/min [18 US gal/min]
Leakage @ at rated pressure	420 cm ³ /min [25.6 in ³ /min]
Weight	0.81 kg [1.79 lb]
Hysteresis	8% maximum
Threshold current	0.2 A (12 VDC coil) 0.1 A (24 VDC coil)
Maximum control current	1.8 A (12 VDC coil) 0.9 A (24 VDC coil)
Pressure differential	0 bar [0 psi] maximum
Cavity	SDC12-2
Standard Coil	D14E(35W) 35 Watt

Theoretical performance

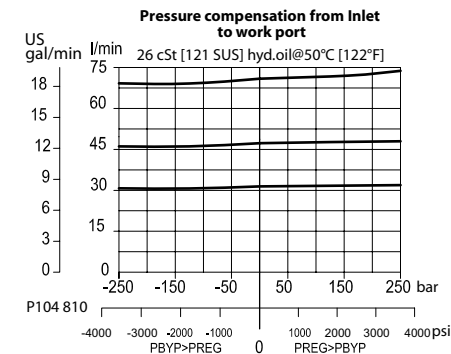
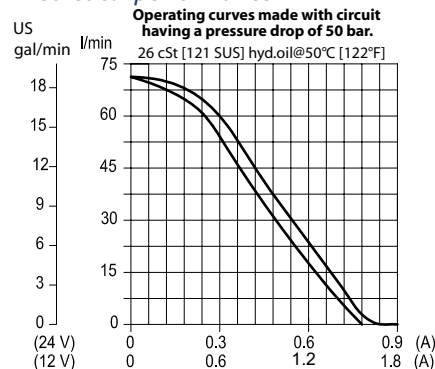

Schematic

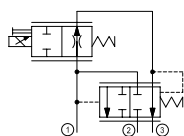

P104 793

DIMENSIONS

mm [in]

Cross-sectional view

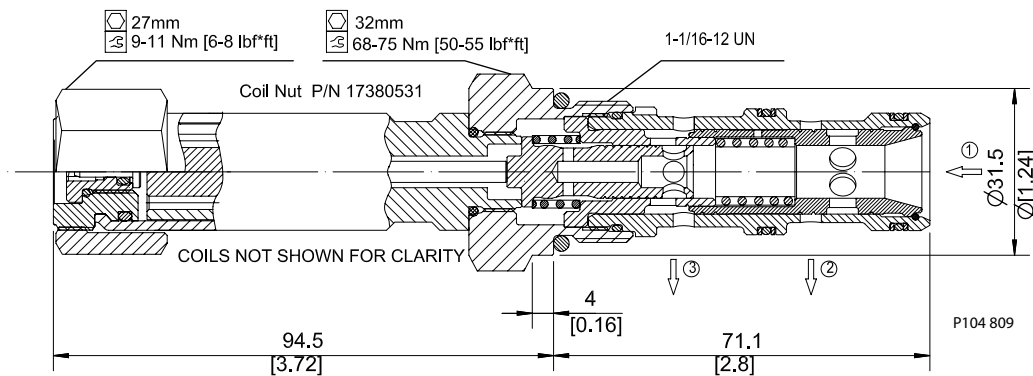

ORDERING INFORMATION

PFC12-PO-70-12D-DN-B-00

Max regulated flow 70 = 70 l/min	Coil voltage 00 = No coil 12D = 12V DC 24D = 24V DC	Coil termination 00 = No coil FL = Flying Lead DN = ISO 4400 (DIN 43650) DE = Deutsch AJ = Amp Junior AS = Amp Superseal	Body and Ports 00 = No housing 10S = Al, #10 SAE 12S = Al, #12 SAE 4B = Al, 1/2 BSP 6B = Al, 3/4 BSP Other housing available	Body Nomencl. No Body CP12-3-10S CP12-3-12S CP12-3-4B CP12-3-6B
			Seals B = Buna-N seals V = Viton	Seal Kit 354008319 354008419

P104 811



Cartridge Valves Technical Information

Proportional valves

PFC16-PO



OPERATION

This is a pressure-compensated, priority-type, normally-open, spool-type, proportional flow-control. Controlled flow is from port 1 to 3, port 2 is bypass.

SPECIFICATIONS

Specifications

Rated pressure	260 bar [3770 psi]
Rated flow at 260 bar [3771 psi]	90 l/min [24 US gal/min]
Leakage	420 cm ³ /min [25.6 in ³ /min] @ at rated pressure
Weight	0.97 kg [2.14 lb]
Hysteresis	8% maximum
Threshold current	0.1 A (12 VDC coil) 0.05 A (24 VDC coil)
Maximum control current	1.8 A (12 VDC coil) 0.9 A (24 VDC coil)
Pressure differential	0 bar [0 psi] maximum
Cavity	SDC16-3
Standard Coil	D14E(35W) 35 Watt

Theoretical performance

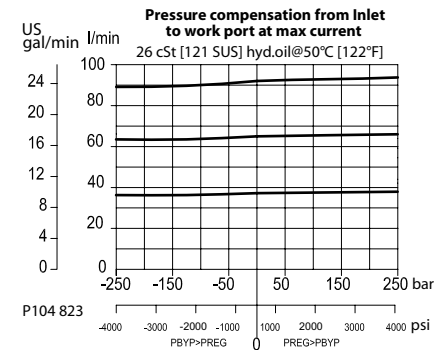
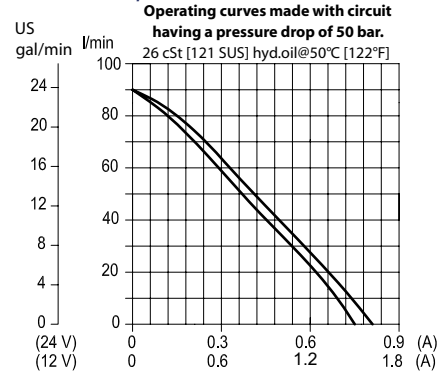

Schematic

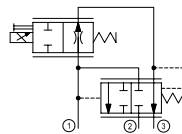

P104 793

DIMENSIONS

mm [in]

Cross-sectional view

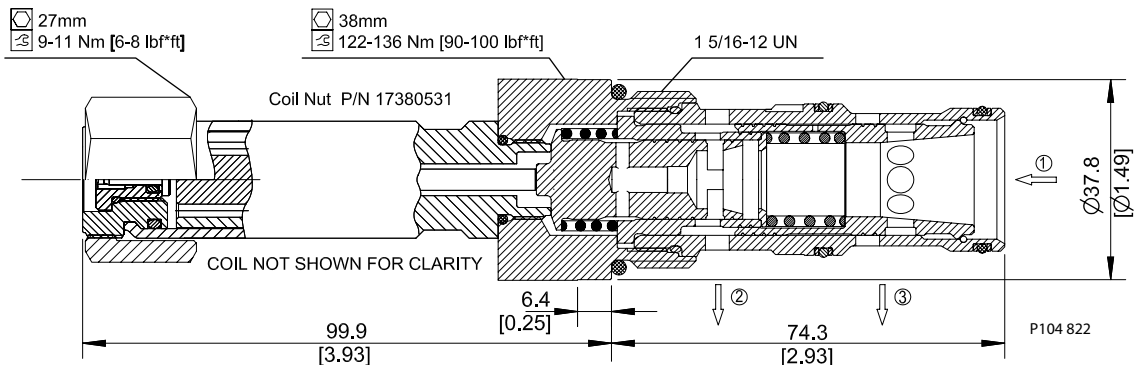

ORDERING INFORMATION

PFC16-PO-90-12D-DN-B-00

Max regulated flow
90 = 90 l/min

Coil voltage
00 = No coil
12D = 12V DC
24D = 24V DC

Coil termination
00 = No coil
FL = Flying Lead
DN = ISO 4400 (DIN 43650)
DE = Deutsch
AJ = Amp Junior
AS = Amp Superseal

Body and Ports
00 = No housing
6B = Al, 3/4 BSP
8B = Al, 1 BSP
12S = Al, #12 SAE
16S = Al, #16 SAE
Other housings available

Seals
B = Buna-N seals
V = Viton seals

Seal Kit
354008919
354009019

Body Nomenclature
No housing
SDC16-3-HE-6B
SDC16-3-HE-8B
CP16-3-12S
CP16-3-16S

P104 824

Proportional valves PFC16-PO

Proportional valves
PFC10-RC

OPERATION

This is a pressure-compensated, restrictive-type, normally-closed, spool-type, proportional flow-control. Controlled flow is from port 1 to 2.

SPECIFICATIONS

Specifications

Rated pressure	260 bar [3770 psi]
Rated flow at 260 bar [3771 psi]	30 l/min [8 US gal/min]
Leakage @ at rated pressure	420 cm ³ /min [25.6 in ³ /min]
Weight	0.65 kg [1.43 lb]
Hysteresis	8% maximum
Threshold current	0.5 A (12 VDC coil) 0.25 A (24 VDC coil)
Maximum control current	1.8 A (12 VDC coil) 0.9 A (24 VDC coil)
Pressure differential	0 bar [0 psi] maximum
Cavity	SDC10-2
Standard Coil	M19P 22 Watt

Theoretical performance

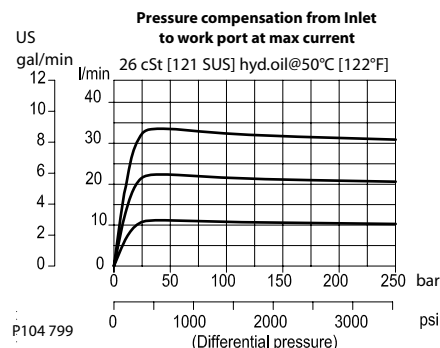
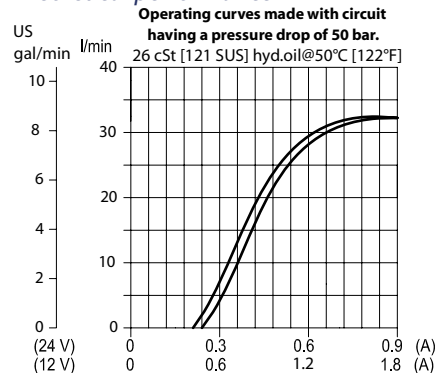

Schematic

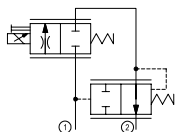

P104 797

DIMENSIONS

mm [in]

Cross-sectional view

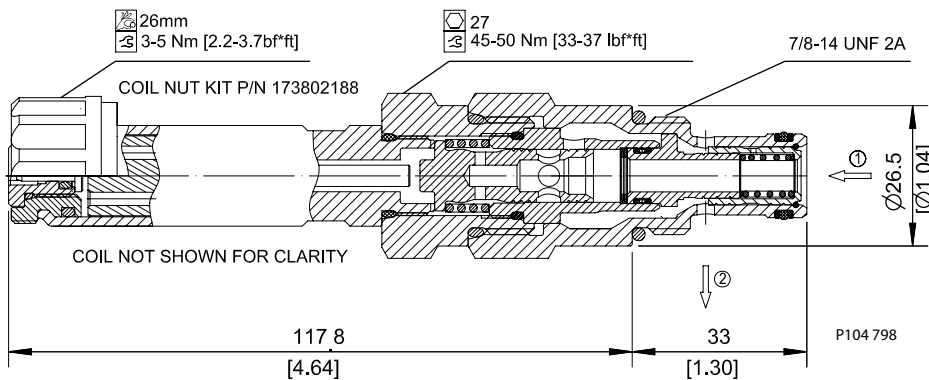

ORDERING INFORMATION

PFC10-RC-30-12D-DN-B-00

Max regulated flow
 30 = 30 l/min

Coil voltage
 00 = No coil
 12D = 12V DC
 24D = 24V DC

Coil termination
 00 = No coil
 FL = Flying Lead
 DN = ISO 4400 (DIN 43650)
 DE = Deutsch

Body and Ports

00 = No housing
 6S = Al, #6 SAE
 8S = Al, #8 SAE
 DG3B = Al, 3/8 BSP
 DG4B = Al, 1/2 BSP
 Other housings available

Seals

B = Buna-N seals
 V = Viton seals

Body Nomenclature

No Body
 CP10-2-6S
 CP10-2-8S
 SDC10-2-DG3B
 SDC10-2-DG4B

P104 800



Cartridge Valves Technical Information

Proportional valves

PFC12-RC



OPERATION

This is a pressure-compensated, restrictive-type, normally-closed, spool-type, proportional flow-control. Controlled flow is from port 1 to 2.

SPECIFICATIONS

Specifications

Rated pressure	260 bar [3770 psi]
Rated flow at 260 bar [3771 psi]	65 l/min [17 US gal/min]
Leakage	420 cm ³ /min [25.6 in ³ /min] @ at rated pressure
Weight	0.77 kg [1.70 lb]
Hysteresis	8% maximum
Threshold current	0.3 A (12 VDC coil) 0.15 A (14 VDC coil)
Maximum control current	1.8 A (12 VDC coil) 0.9 A (14 VDC coil)
Pressure differential	0 bar [0 psi] maximum
Cavity	SDC12-2
Standard Coil	D14E(35W) 35 Watt

Theoretical performance

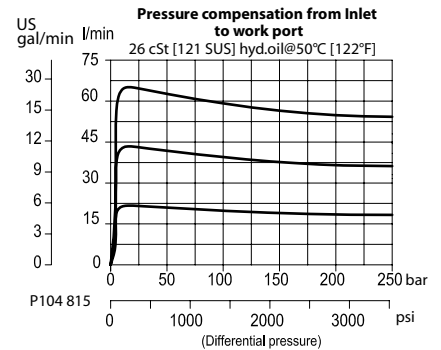
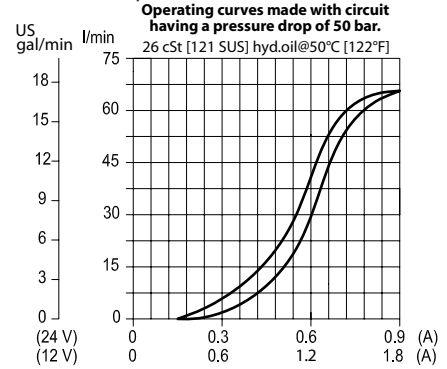

Schematic

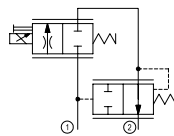

P104 797

DIMENSIONS

mm [in]

Cross-sectional view

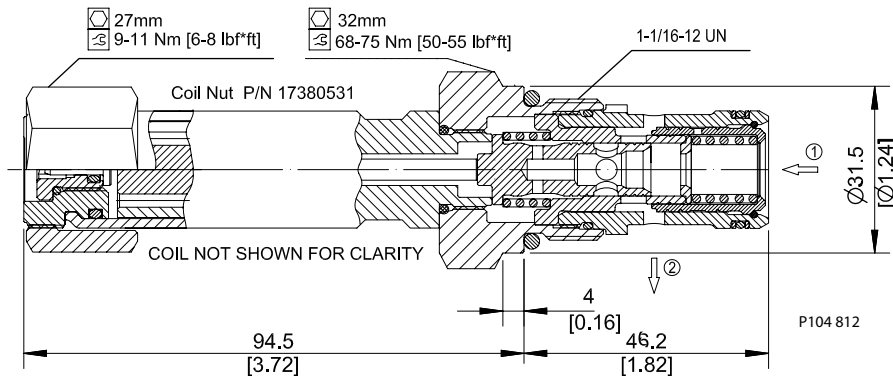

ORDERING INFORMATION

PFC12-RC-65-12D-DN-B-00

Max regulated flow
65 = 65 l/min

Coil voltage
00 = No coil
12D = 12V DC
24D = 24V DC

Coil termination
00 = No coil
FL = Flying Lead
DN = ISO 4400 (DIN 43650)
DE = Deutsch
AJ = Amp Junior
AS = Amp Superseal

Body and Ports
00 = No housing
10S = Al, #10 SAE
12S = Al, #12 SAE
DG4B = Al, 1/2 BSP
DG6B = Al, 3/4 BSP
Other housing available

Seals
B = Buna-N seals
V = Viton

Seal Kit
354008319
354008419

Body Nomencl.
No Body
CP12-2-10S
CP12-2-12S
SDC12-2-DG4B
SDC12-2-DG6B

P104 814

Proportional valves
PFC16-RC

OPERATION

This is a pressure-compensated, restrictive-type, normally-closed, spool-type, proportional flow control. Controlled flow is from port 1 to 2.

SPECIFICATIONS

Specifications

Rated pressure	260 bar [3770 psi]
Rated flow at 260 bar [3771 psi]	90 l/min [24 US gal/min]
Leakage	420 cm ³ /min [25.6 in ³ /min] @ at rated pressure
Weight	0.91 kg [2.01 lb]
Hysteresis	8% maximum
Threshold current	0.4 A (12 VDC coil) 0.2 A (24 VDC coil)
Maximum control current	1.8 A (12 VDC coil) 0.9 A (24 VDC coil)
Pressure differential	0 bar [0 psi] maximum
Cavity	SDC16-2
Standard Coil	D14E(35W) 35 Watt

Theoretical performance

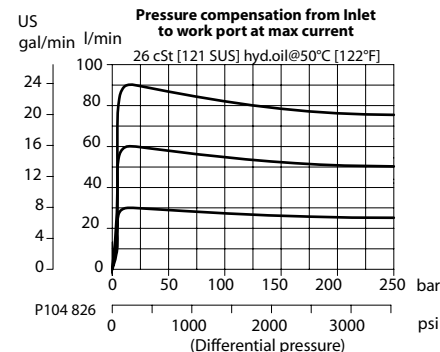
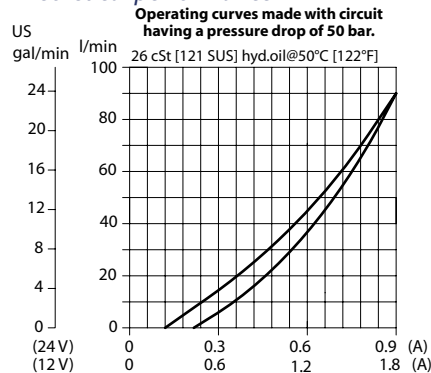

Schematic

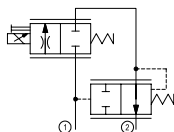

P104 797

DIMENSIONS

mm [in]

Cross-sectional view

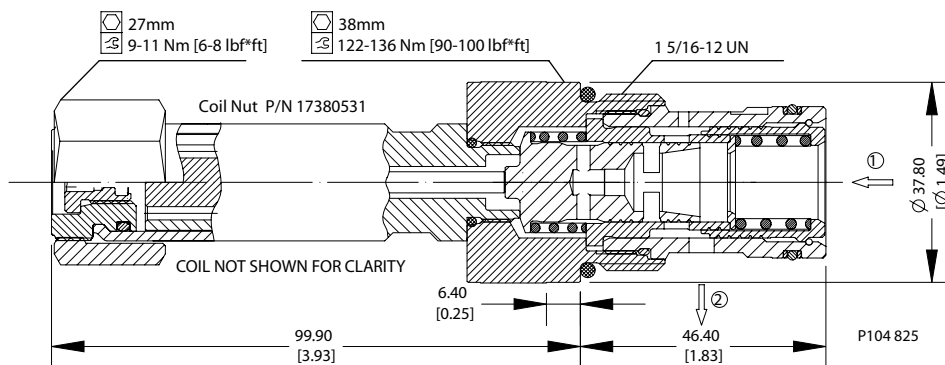

ORDERING INFORMATION

PFC16-RC-90-12D-DN-B-00

Max regulated flow
90 = 90 l/min

Coil voltage
 00 = No coil
 12D = 12V DC
 24D = 24V DC

Coil termination
 00 = No coil
 FL = Flying Lead
 DN = ISO 4400 (DIN 43650)
 DE = Deutsch
 AJ = Amp Junior
 AS = Amp Superseal

Body and Ports
 00 = No housing
 DG6B = Al, 3/4 BSP
 DG8B = Al, 1 BSP
 12S = Al, #12 SAE
 16S = Al, #16 SAE
 Other housing available

Seals
 B = Buna-N seals
 V = Viton

Seal Kit
 354008719
 354008819

Body Nomencl.
 No Body
 SDC16-2-DG-6B
 SDC16-2-DG-8B
 CP16-2-12S
 CP16-2-16S

P104 827



Cartridge Valves Technical Information

Proportional valves PFC10-RO



OPERATION

This is a pressure-compensated, restrictive-type, normally-open, spool-type, proportional flow-control. Controlled flow is from port 1 to 2.

SPECIFICATIONS

Specifications

Rated pressure	260 bar [3770 psi]
Rated flow at 260 bar [3771 psi]	30 l/min [8 US gal/min]
Leakage	420 cm ³ /min [25.6 in ³ /min] @ at rated pressure
Weight	0.65 kg [1.43 lb]
Hysteresis	8% maximum
Threshold current	0.2 A (12 VDC coil) 0.1 A (24 VDC coil)
Maximum control current	1.8 A (12 VDC coil) 0.9 A (24 VDC coil)
Pressure differential	0 bar [0 psi] maximum
Cavity	SDC10-2
Standard Coil	M19P 22 Watt

Theoretical performance

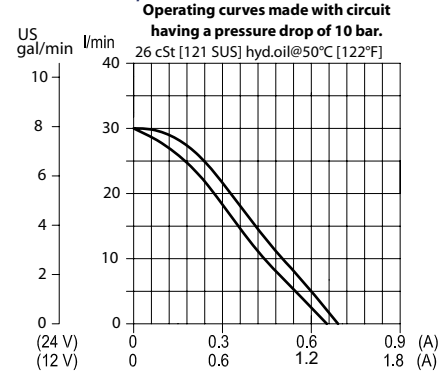

Schematic

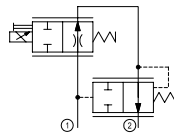

P104 802

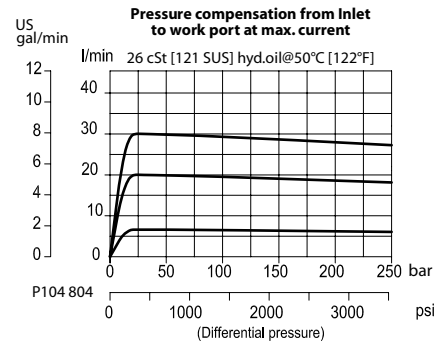

DIMENSIONS

mm [in]

Cross-sectional view

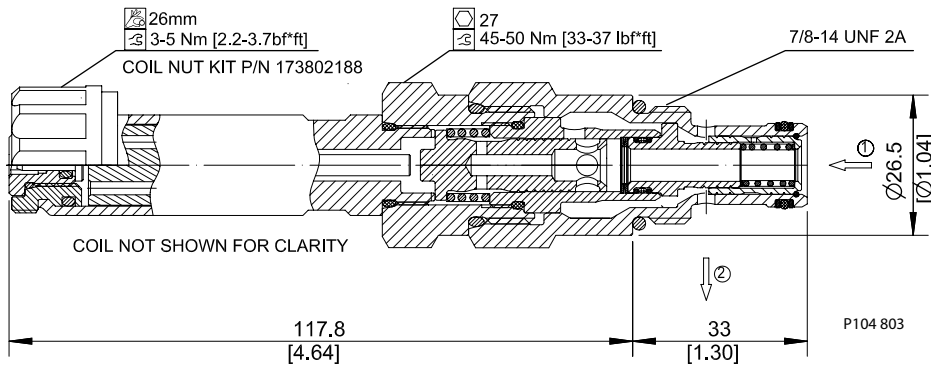

P104 803

ORDERING INFORMATION

PFC10-RO-30-12D-DN-B-00

Max regulated flow
30 = 30 l/min

Coil voltage
00 = No coil
12D = 12V DC
24D = 24V DC

Coil termination
00 = No coil
FL = Flying Lead
DN = ISO 4400 (DIN 43650)
DE = Deutsch

Body and Ports

00 = No housing
6S = Al, #6 SAE
8S = Al, #8 SAE
DG3B = Al, 3/8 BSP
DG4B = Al, 1/2 BSP
Other housing available

Seals

B = Buna-N seals 35400401
V = Viton seals 35400341

Seal Kit

35400401
35400341

Body Nomenclature

No Body
CP10-2-6S
CP10-2-8S
SDC10-2-DG3B
SDC10-2-DG4B

P104 805

Proportional valves
PFC12-RO

OPERATION

This is a pressure-compensated, restrictive-type, normally-open, spool-type, proportional flow-control. Controlled flow is from port 1 to 2.

SPECIFICATIONS

Specifications

Rated pressure	260 bar [3770 psi]
Rated flow at 260 bar [3771 psi]	60 l/min [16 US gal/min]
Leakage @ at rated pressure	420 cm ³ /min [25.6 in ³ /min]
Weight	0.77 kg [1.70 lb]
Hysteresis	8% maximum
Threshold current	0.42 A (12 VDC coil) 0.21 A (24 VDC coil)
Maximum control current	1.8 A (12 VDC coil) 0.9 A (24 VDC coil)
Pressure differential	0 bar [0 psi] maximum
Cavity	SDC12-2
Standard Coil	D14E(35W) 35 Watt

Theoretical performance

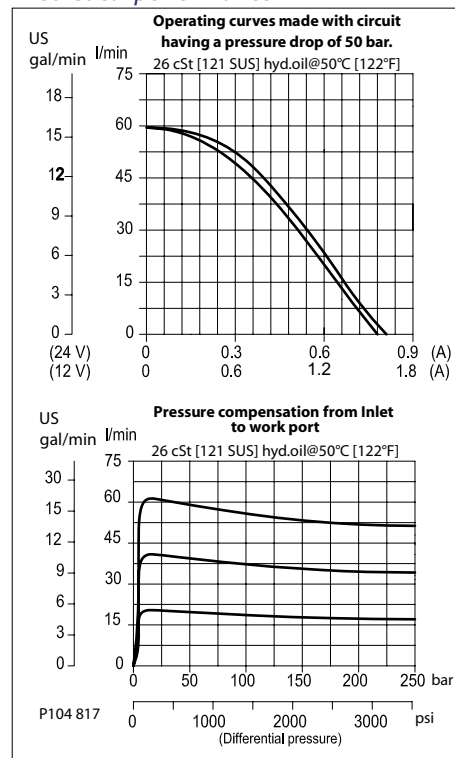

Schematic

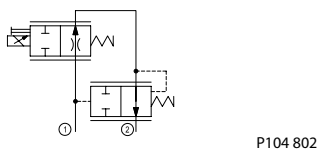

DIMENSIONS

mm [in]

Cross-sectional view

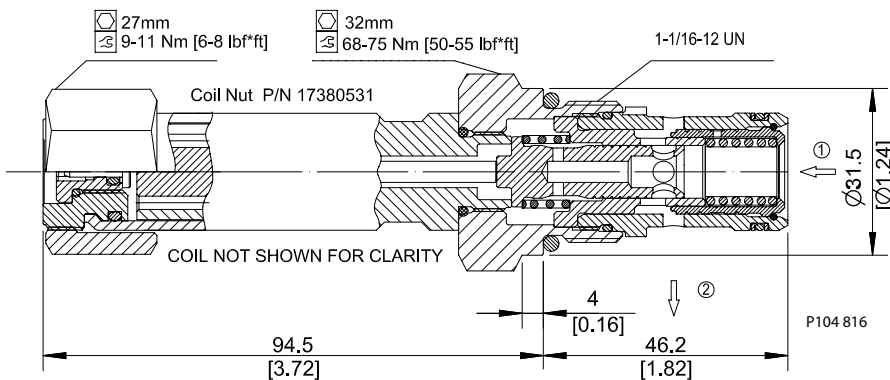

ORDERING INFORMATION

PFC12-RO-60-12D-DN-B-00

Max regulated flow
60 = 60 l/min

Coil voltage
 00 = No coil
 12D = 12V DC
 24D = 24V DC

Coil termination
 00 = No coil
 FL = Flying Lead
 DN = ISO 4400 (DIN 43650)
 DE = Deutsch
 AJ = Amp Junior
 AS = Amp Superseal

Body and Ports
 00 = No housing
 10S = Al, #10 SAE
 12S = Al, #12 SAE
 DG4B = Al, 1/2 BSP
 DG6B = Al, 3/4 BSP
 Other housing available

Seals Seal Kit
 B = Buna-N seals 354008319
 V = Viton 354008419

Body Nomencl.
 No Body
 CP12-2-10S
 CP12-2-12S
 SDC12-2-DG4B
 SDC12-2-DG6B

P104 818



Cartridge Valves Technical Information

Proportional valves

PFC16-RO



OPERATION

This is a pressure-compensated, restrictive-type, normally-open, spool-type, proportional flow-control. Controlled flow is from port 1 to 2.

SPECIFICATIONS

Specifications

Rated pressure	260 bar [3770 psi]
Rated flow at 260 bar [3771 psi]	85 l/min [22 US gal/min]
Leakage	420 cm ³ /min [25.6 in ³ /min] @ at rated pressure
Weight	0.91 kg [2.01 lb]
Hysteresis	8% maximum
Threshold current	0.2 A (12 VDC coil) 0.1 A (24 VDC coil)
Maximum control current	1.8 A (12 VDC coil) 0.9 A (24 VDC coil)
Pressure differential	0 bar [0 psi] maximum
Cavity	SDC16-2
Standard Coil	D14E(35W) 35 Watt

Theoretical performance

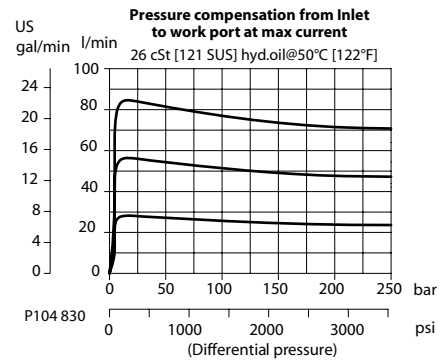
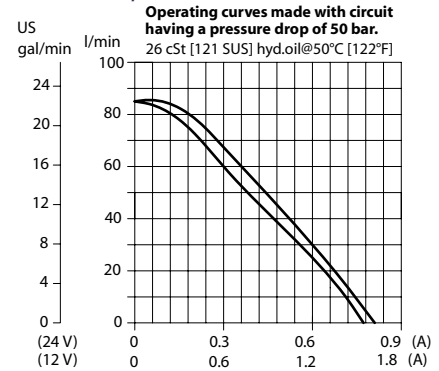

Schematic

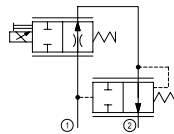

P104 802

DIMENSIONS

mm [in]

Cross-sectional view

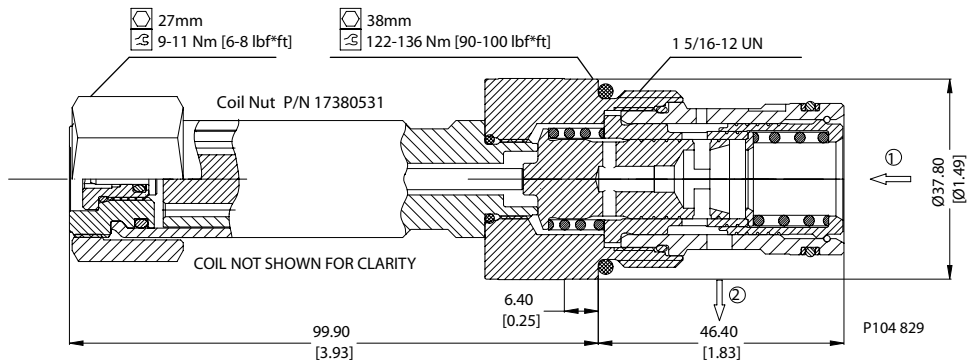

P104 829

ORDERING INFORMATION

PFC16-RO-85-12D-DN-B-00

Max regulated flow
85 = 85 l/min

Coil voltage
00 = No coil
12D = 12V DC
24D = 24V DC

Coil termination
00 = No coil
FL = Flying Lead
DN = ISO 4400 (DIN 43650)
DE = Deutsch
AJ = Amp Junior
AS = Amp Superseal

Body and Ports
00 = No housing
DG6B = Al, 3/4 BSP
DG8B = Al, 1 BSP
12S = Al, #12 SAE
16S = Al, #16 SAE
Other housing available

Seals
B = Buna-N seals
V = Viton

P104 831

Body Nomencl.
No Body
SDC16-2-DG-6B
SDC16-2-DG-8B
CP16-2-12S
CP16-2-16S

Proportional valves
 XMD 04

OPERATION

This is a direct-acting normally-open, proportional relief valve.

SPECIFICATIONS

Specifications

Rated pressure	250 bar [3600 psi]
Rated flow at 7 bar [100 psi]	5 l/min [1 US gal/min]
Weight	0.44 kg [0.97 lb]
Hysteresis	3% maximum
Threshold current	0 A (12 VDC coil) 0 A (24 VDC coil)
Maximum control current	1.8 A (12 VDC coil) 0.9 A (24 VDC coil)
Cavity	NCS04/2
Standard Coil	M19P 22 Watt

Theoretical performance

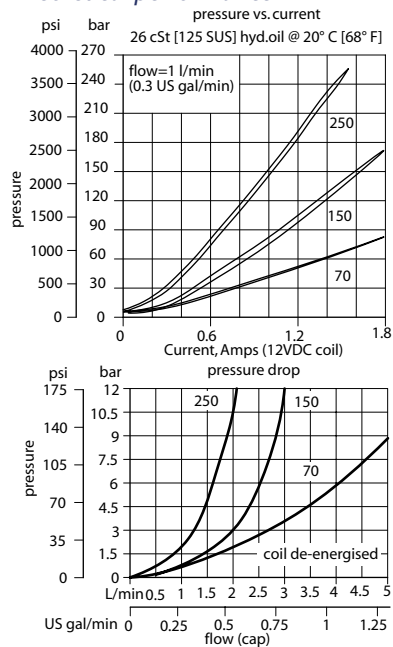

Schematic

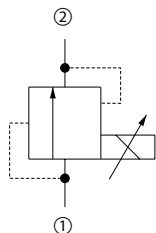

DIMENSIONS

mm [in]

Cross-sectional view

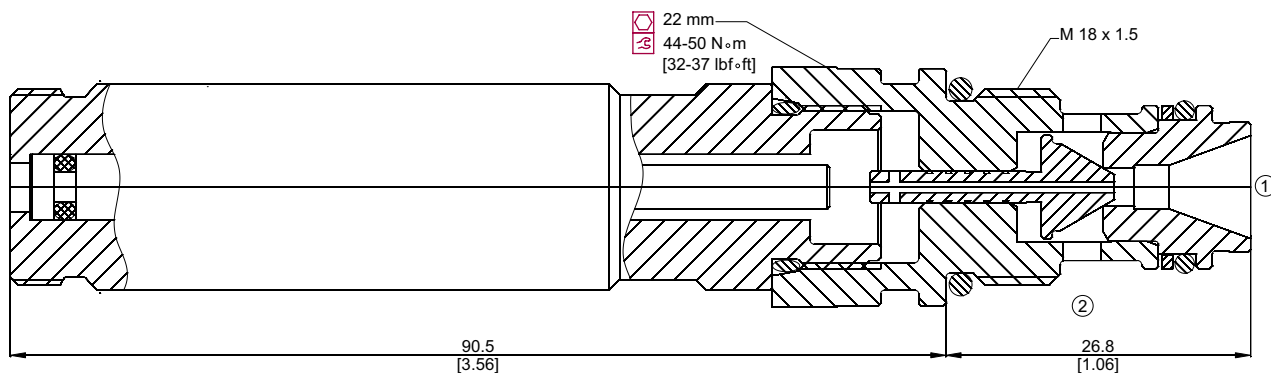

ORDERING INFORMATION

XMD 04 - 70 - 24C - A - EN - 00 - V

Setting range

70 = 3-75 bar [44-1088 psi]
 150 = 4-160 bar [58-2321 psi]
 250 = 7-250 bar [102-3626 psi]

Voltage

00 = No coil
 12C = 12 VDC coil
 24C = 24 VDC coil

Termination

0 = No connector FL600 = Lead wires
 A = DIN 43650 DE = Deutsch
 AMJ = AMP Junior

Seals
 V = Viton
 Omit = Buna-N

Housing and ports

00 = No Housing
 DG1/4 = AL, 1/4 BSP
 DG4S = AL, #4 SAE
 DG6S = AL, #6 SAE
 Other housings available

Manual override
 00 = Push control (Standard)
 EN = Screw control

Seal kit
 230000390
 230000190

Housing P/N

No Housing
 NCS04/2-DG-1/4
 NCS04/2-DG-4S
 NCS04/2-DG-6S



Cartridge Valves Technical Information

Proportional valves

CP558-20



OPERATION

This valve is a direct acting, normally-open, proportional valve.

SPECIFICATIONS

Specifications

Rated pressure	210 bar [3000 psi]
Rated flow at 7 bar [100 psi]	8 l/min [2 US gal/min]
Weight	0.48 kg [1.06 lb]
Hysteresis	10% maximum
Threshold current	0 A (12 VDC coil) 0 A (24 VDC coil)
Maximum control current	1.2 A (12 VDC coil) 0.6 A (24 VDC coil)
Cavity	SDC08-2
Standard Coil	D10 30 Watt
Coil nut	321978

Theoretical performance

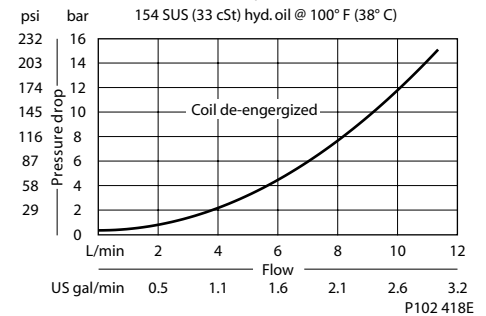
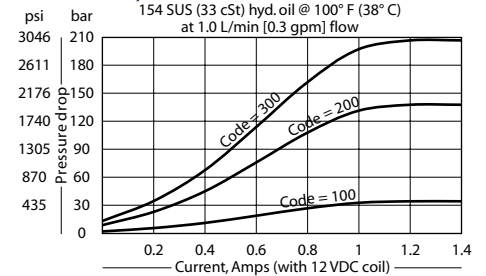

Schematic

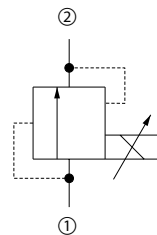

DIMENSIONS

mm [in]

Cross-sectional view

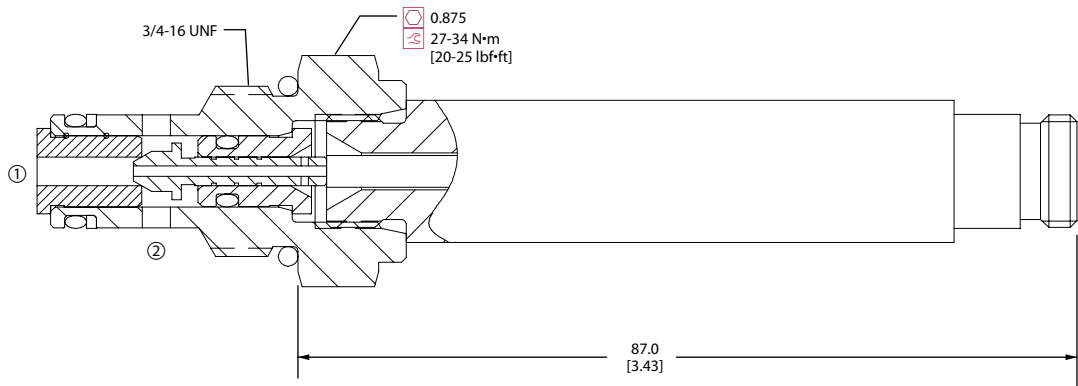

ORDERING INFORMATION

CP558 - 20 - B - 6S - 300 - 24D - H

Seals
B = Buna-N
V = Viton

Housing and ports
0 = No Housing
DG2B = AL, 1/4 BSP
DG3B = AL, 3/8 BSP
4S = AL, #4 SAE
6S = AL, #6 SAE
Other housings available

Housing P/N
No Housing
SDC08-2-DG-2B
SDC08-2-DG-3B
CP08-2-4S
CP08-2-6S

Seal kit
120221
120222

Voltage
000 = No coil
12D = 12 VDC coil
24D = 24 VDC coil

Pressure code
050 = 35 bar [500 psi] max
100 = 69 bar [1000 psi] max
200 = 138 bar [2000 psi] max
300 = 207 bar [3000 psi] max

Termination
00 = No connector
H = DIN 43650
L = Lead wires
DE = Deutsch
M2 = Metripack 150 Type 1
S = Spade

P102 412E

OPERATION

This is a pilot-operated, normally-open, proportional relief valve.

SPECIFICATIONS

Specifications

Rated pressure	315 bar [4500 psi]
Rated flow at 7 bar [100 psi]	50 l/min [13 US gal/min]
Weight	0.53 kg [1.17 lb]
Hysteresis	3% maximum
Threshold current	0 A (12 VDC coil) 0 A (24 VDC coil)
Maximum control current	1.8 A (12 VDC coil) 0.9 A (24 VDC coil)
Cavity	NCS06/2
Standard Coil	M19P 22 Watt

Theoretical performance

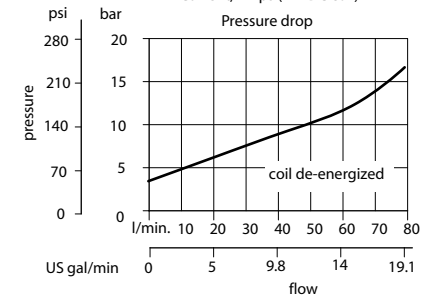
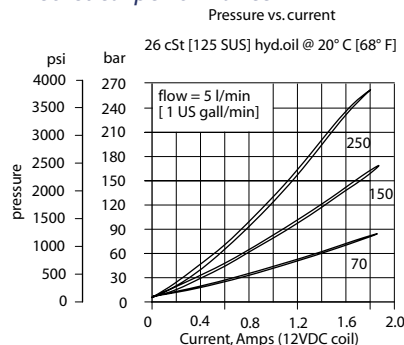

Schematic

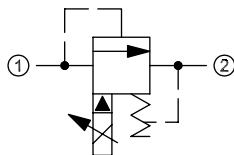

P103 512

P103 697E

DIMENSIONS

mm [in]

Cross-sectional view

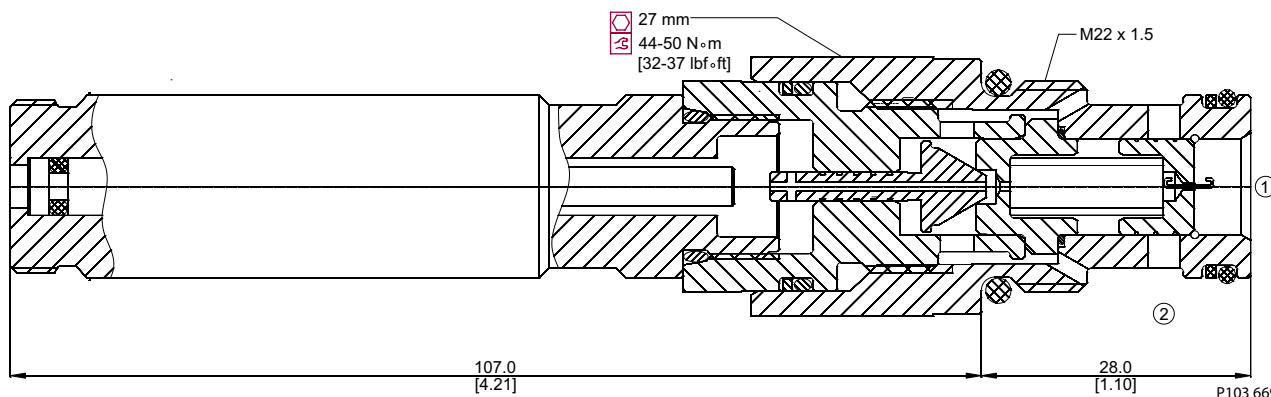

P103 669

ORDERING INFORMATION

XMP 06 - 70 - 24C - A - EN - 00 - V

Setting range

- 70 = 3-70 bar [44-1015 psi]
- 150 = 5-150 bar [73-2176 psi]
- 250 = 7-250 bar [102-3626 psi]

Standard solenoid and connector (DIN 43650)

- 12C-A = 12VDC solenoid with type A connector
- 24C-A = 24VDC solenoid with type A connector

Seals

- V = Viton Seals
- Ignore for Buna-N

Housings and Ports

- 0 = Cartridge
- SE-4B ½"BS PP, Alum
- SE-6S #6 SAE, Alum
- SE-8S #8 SAE, Alum
- other styles available

Manual override

- 00 = With pushing control (Standard)
- EN = With screw control

P103 724E



Cartridge Valves Technical Information

Proportional valves

PRV10



OPERATION

This is a normally-closed, pilot-operated, proportional relief valve.

SPECIFICATIONS

Specifications

Rated pressure	250 bar [3600 psi]
Rated flow at 7 bar [100 psi]	76 l/min [20 US gal/min]
Weight	0.53 kg [1.17 lb]
Hysteresis	10% maximum
Threshold current	0 A (12 VDC coil) 0 A (24 VDC coil)
Maximum control current	1.4 A (12 VDC coil) 0.7 A (24 VDC coil)
Cavity	SDC10-2
Standard Coil	M19P 22 Watt

Theoretical performance

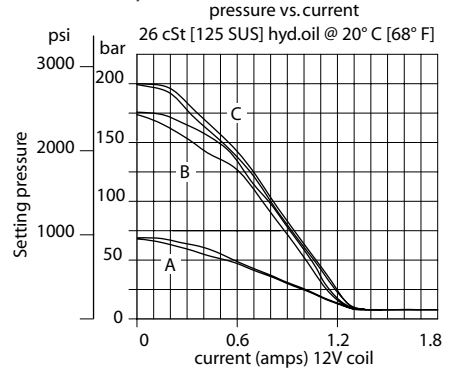

Schematic

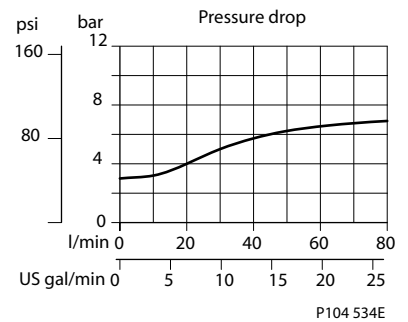
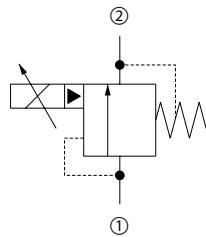

DIMENSIONS

mm [in]

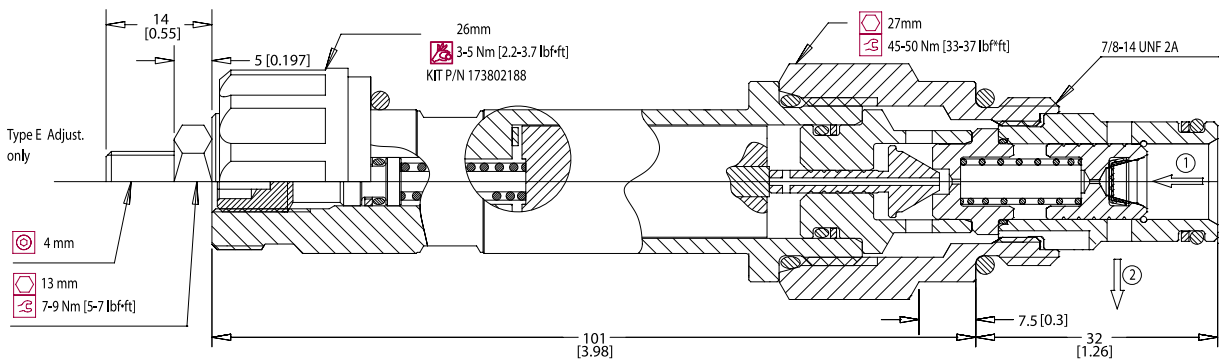

ORDERING INFORMATION

PRV10-POC-215-C-12-DT-F-B-00

<p>Crack pressure Code = Setting in bar</p> <p>Standard settings 55 = 55 bar [800 psi] Range A 135 = 135 bar [1960 psi] Range B 215 = 215 bar [3120 psi] Range C</p> <p>Pressure range A= 25 - 65 bar [360 - 940 psi] B= 65 - 155 bar [940-2250 psi] C= 155 - 215 bar [2250-3120 psi]</p>	<p>Voltage 00 = No coil 12 = 12 VDC 24 = 24 VDC</p>	<p>Housing and ports 00 = No Housing DG3B = AL, 3/8 BSP DG4B = AL, 1/2 BSP 65 = AL, #6 SAE 85 = AL, #8 SAE Other housings available</p>	<p>Housing P/N No Housing SDC10-2-DG-3B SDC10-2-DG-4B CP10-2-6S CP10-2-8S</p>
<p>Termination 0 = No connector DE = Deutsch FL = Lead wires</p>	<p>Seals B = Buna-N V = Viton</p>	<p>Seal Kit 35400071 35400081</p>	<p>Adjustment option: E = External F = Tamper resistant H = Hidden</p>

P103 776E

Proportional valves
PRV12

OPERATION

This is a normally-closed, pilot-operated, proportional relief valve.

SPECIFICATIONS

Specifications

Rated pressure	250 bar [3600 psi]
Rated flow at 7 bar [100 psi]	180 l/min [48 US gal/min]
Weight	0.62 kg [1.37 lb]
Hysteresis	10% maximum
Threshold current	0 A (12 VDC coil) 0 A (24 VDC coil)
Maximum control current	1.5 A (12 VDC coil) 0.8 A (24 VDC coil)
Cavity	SDC12-2
Standard Coil	M19P 22 Watt

Theoretical performance

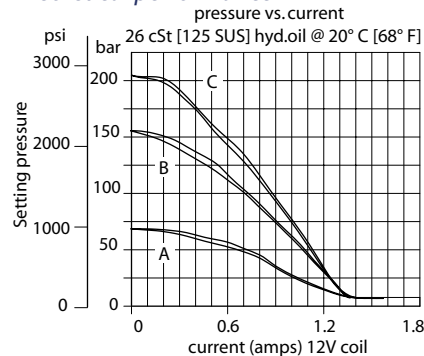

Schematic

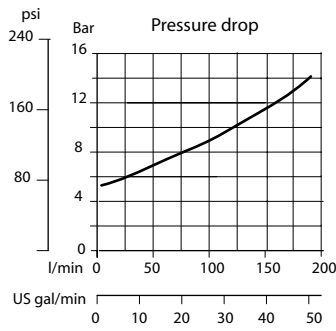
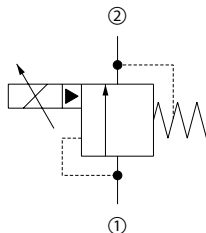

DIMENSIONS

mm [in]

Cross-sectional view

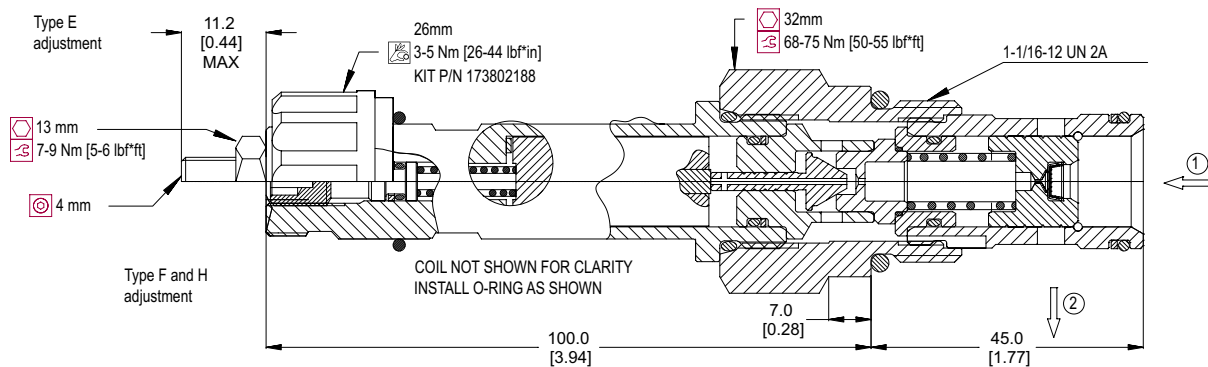

ORDERING INFORMATION

PRV12-POC-215-C-12-DT-F-B-00

<p>Crack pressure Code = Setting in bar</p> <p>Standard settings 55 = 55 bar [800 psi] Range A 135 = 135 bar [1960 psi] Range B 215 = 215 bar [3120 psi] Range C</p> <p>Pressure range A= 25 - 65 bar [360 - 940 psi] B= 65 - 155 bar [940-2250 psi] C= 155 - 215 bar [2250-3120 psi]</p> <p>Termination 0 = No connector DE = Deutsch DN = DIN 43650 FL = Lead wires</p>	<p>Voltage 00 = No coil 12 = 12 VDC 24 = 24 VDC</p>	<p>Housing and ports 00 = No Housing DG4B = AL, 1/2 BSP DG6B = AL, 3/4 BSP 105 = AL, #10 SAE 125 = AL, #12 SAE Other housings available</p> <p>Seals B = Buna-N V = Viton</p> <p>Seal Kit 35400131 35400181</p> <p>Adjustment option: E = External F = Tamper resistant H = Hidden</p>	<p>Housing P/N No Housing SDC12-2-DG-4B SDC12-2-DG-6B SDC-12-10S SDC-12-16S</p>
---	--	--	--



Cartridge Valves Technical Information

Proportional valves

XRP 06



OPERATION

This is a pilot-operated, proportional pressure reducing/relieving valve.

SPECIFICATIONS

Specifications

Rated pressure	315 bar [4500 psi]
Rated flow at 7 bar [100 psi]	25 l/min [7 US gal/min]
Weight	0.55 kg [1.21 lb]
Hysteresis	3% maximum
Threshold current	0 A (12 VDC coil) 0 A (24 VDC coil)
Maximum control current	1.8 A (12 VDC coil) 0.9 A (24 VDC coil)
Cavity	NCS06/3
Standard Coil	M19P 22 Watt

Theoretical performance

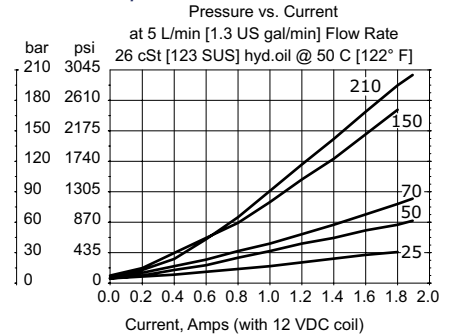

Schematic

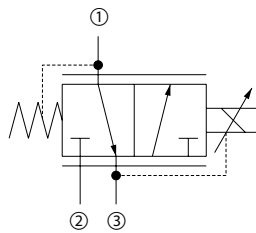

P102 433E

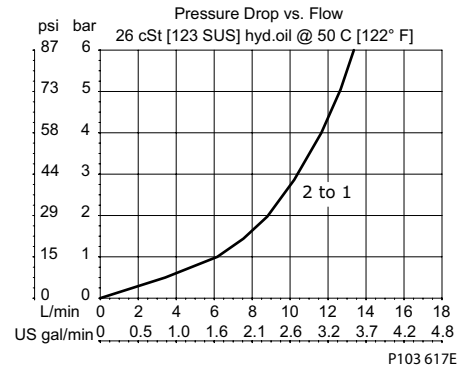

P103 617E

DIMENSIONS

mm [in]

Cross-sectional view

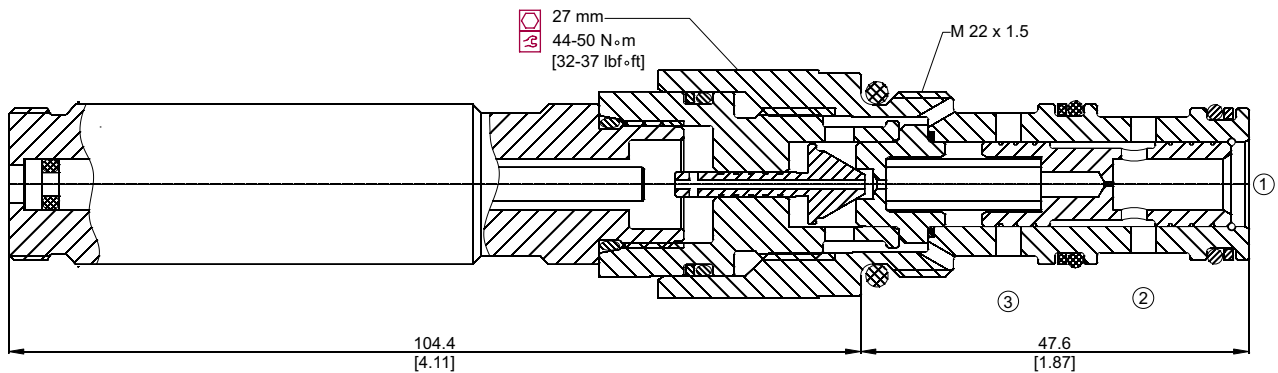

P103 612

ORDERING INFORMATION

XRP 06 - 70 - 12C - A - EN - 00 - V

Setting range

- 25 = 6-25 bar [90-360 psi]
- 50 = 6-55 bar [90-800 psi]
- 70 = 5-75 bar [90-1100 psi]
- 150 = 8-155 bar [120-2200 psi]
- 210 = 9-210 bar [130-3100 psi]

Voltage

- 00 = No coil
- 12C = 12 VDCI
- 24C = 24 VDC

Termination

- 00 = No connector
- FL600 = Lead wires
- A = DIN 43650
- DE = Deutsch
- AMJ = AMP Jr.

Seals

- V = Viton
- Omit = Buna-N

Seals

- 230000110
- 230000070

Housing and ports

- 00 = No Housing
- SE6S = AL, #6 SAE
- SE8S = AL, #8 SAE
- SE3/8 = AL, 3/8 BSP
- SE1/2 = AL, 1/2 BSP

Housing P/N

- No Housing
- NCS06/3-SE-6S
- NCS06/3-SE-8S
- NCS06/3-SE-3/8
- NCS06/3-SE-1/2

Manual override

- 00 = Push control (Standard)
- EN = Screw control

P103 732E

OPERATION

This valve is a direct acting, proportional, pressure reducing/relieving valve.

SPECIFICATIONS

Specifications

Rated pressure	34 bar [500 psi]
Rated flow at 7 bar [100 psi]	4 l/min [1 US gal/min]
Weight	0.27 kg [0.60 lb]
Hysteresis	10% maximum
Threshold current	0.1 A (12 VDC coil) 0.05 A (24 VDC coil)
Maximum control current	1 A (12 VDC coil) 0.5 A (24 VDC coil)
Cavity	SDC08-3
Standard Coil	D08 16 Watt
Coil nut	322399

Theoretical performance

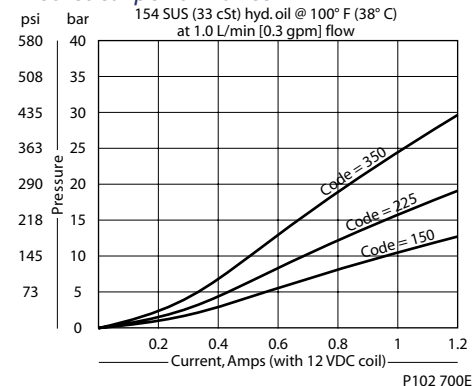

Schematic

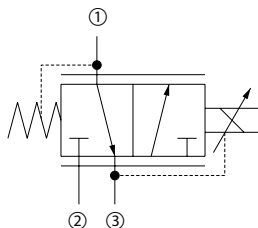

P102 433E

DIMENSIONS

mm [in]

Cross-sectional view

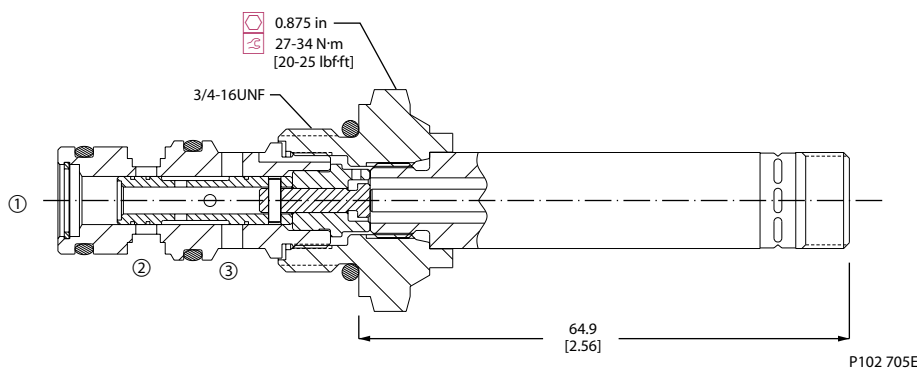

ORDERING INFORMATION

CP558-24-B-4S-150-12D-H

<p>Seals</p> <p>B = Buna-N V = Viton</p> <p>Seal Kit</p> <p>11016151 120708</p>	<p>Housing and ports</p> <p>00 = No Housing SE2B = AL, 1/4 BSP SE3B = AL, 3/8 BSP 4S = AL, #4 SAE 6S = AL, #6 SAE</p> <p>Housing P/N</p> <p>No Housing SDC08-3-SE-2B SDC08-3-SE-3B CP08-3-4S CP08-3-6S</p>	<p>Pressure Code</p> <p>150 = 10.3 bar [150 psi] 225 = 15.5 bar [225 psi] 350 = 24.1 bar [350 psi]</p>	<p>Voltage</p> <p>000 = No coil 12D = 12 VDC coil 24D = 24 VDC coil</p>	<p>Connector</p> <p>0 = No connector H = DIN 43650 L = Lead S = Spade AJ = Amp Junior M2 = Metripak 150 Type 1 DE = Deutsch</p>
---	--	---	--	--

P102 708E



Cartridge Valves Technical Information

Proportional valves

XRP 044



OPERATION

This is a pilot-operated, proportional pressure reducing/relieving valve.

SPECIFICATIONS

Specifications

Rated pressure	50 bar [700 psi]
Rated flow at 7 bar [100 psi]	25 l/min [7 US gal/min]
Weight	0.34 kg [0.75 lb]
Hysteresis	6% maximum
Threshold current	0.15 A (12 VDC coil) 0.08 A (24 VDC coil)
Maximum control current	0.8 A (12 VDC coil) 0.4 A (24 VDC coil)
Cavity	SDC10-4
Standard Coil	M13 20 Watt

Theoretical performance

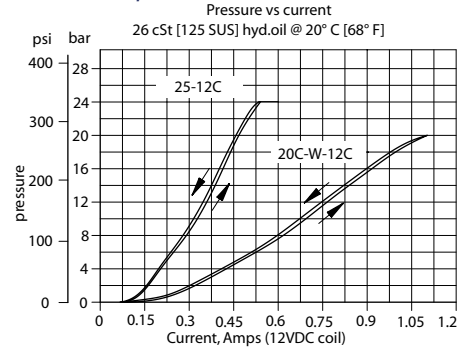

Schematic

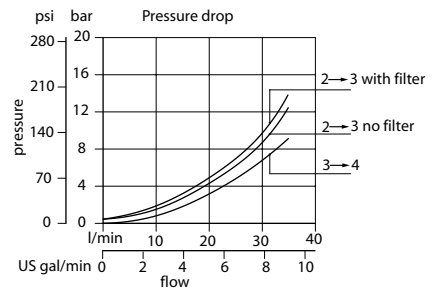
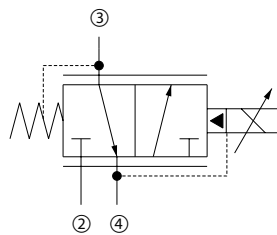

P103 705E

DIMENSIONS

mm [in]

Cross-sectional view

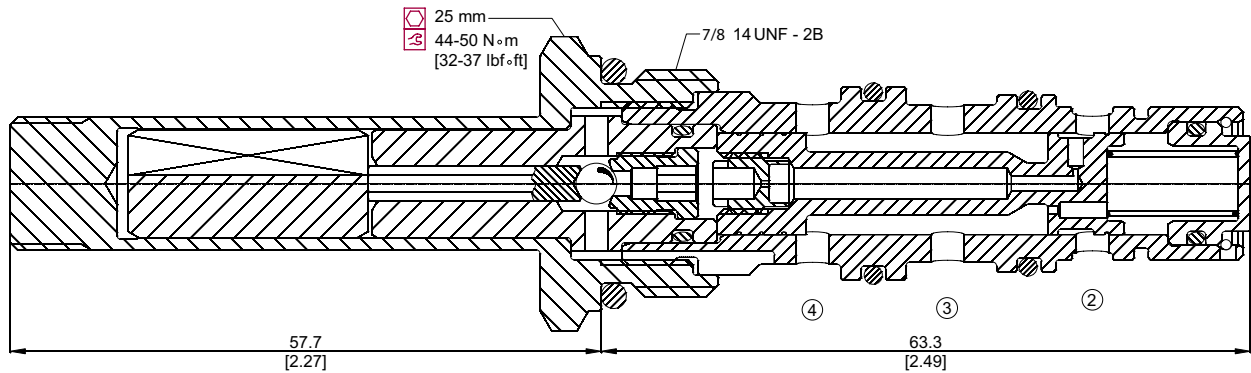

P103 678

ORDERING INFORMATION

XRP 044 / 25* - F - 24C - A - 00 - V

Inlet filter
F = 300 µm filter
Omit = No filter

Voltage
0 = No coil
12C = 12 VDC coil
24C = 24 VDC coil

Termination
0 = No connector
AJ = AMP junior
AMS = AMP superseal 1.5
DE = Deutsch
DN = DIN 43650
FL600 = Lead wires
SP = Spade

Seals
V = Viton
Omit = Buna-N

Seal kit
Consult factory

Housing and ports
00 = No Housing
L3/8 = AL, 3/8 BSP
L1/2 = AL, 1/2 BSP
6S = AL, #6 SAE
8S = AL, #8 SAE
Other housings available

Housing P/N
No Housing
SDC10-4-L-3/8
SDC10-4-L-1/2
CP10-4-6S
CP10-4-8S

* other pressure ranges available, consult factory
BLN-10201 • 520L0588 • Rev. CA • Nov 2007

P103 733E

Proportional valves
PPR10-PAC

OPERATION

This is a pilot-operated, proportional pressure-reducing/relieving valve (inverse functioning).

SPECIFICATIONS

Specifications

Rated pressure	250 bar [3625 psi]
Rated flow at 7 bar [100 psi]	18 l/min [5 US gal/min]
Weight	0.62 kg [1.37 lb]
Hysteresis	10% maximum
Threshold current	0 A (12 VDC coil) 0 A (24 VDC coil)
Maximum control current	1.4 A (12 VDC coil) 0.7 A (24 VDC coil)
Pressure differential	0 bar [0 psi] maximum
Cavity	SDC10-3
Standard Coil	M19P 22 Watt

Theoretical performance

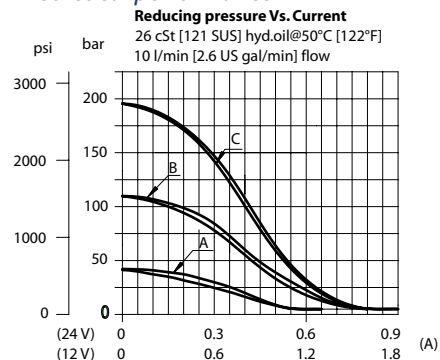

Schematic

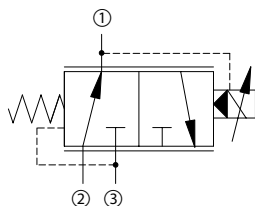

P104 895

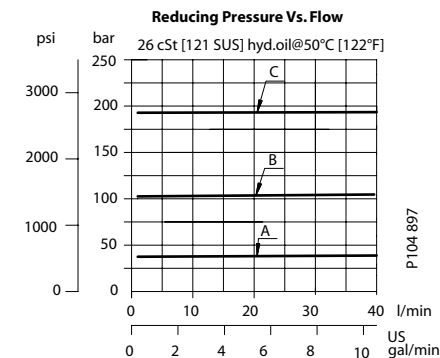

P104 897

DIMENSIONS

mm [in]

Cross-sectional view

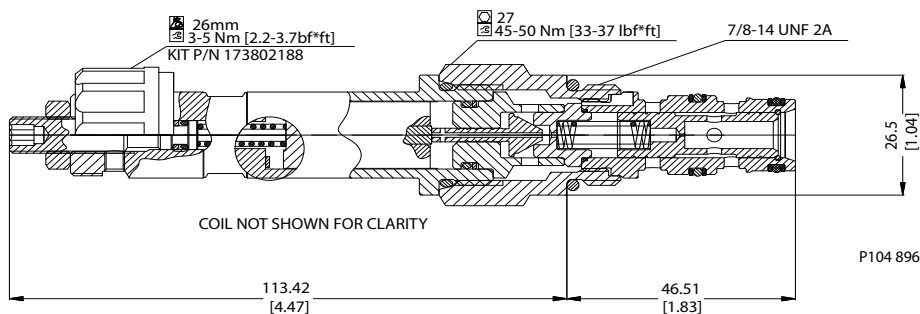

P104 896

ORDERING INFORMATION

PPR10-PAC-40-A-12D-DN-B-00

Cracking pressure

Code = Setting in Bar
 Std. setting
 40 = 40 bar setting (type A)
 100 = 100 bar setting (type B)
 200 = 200 bar setting (type C)

Pressure range

A= 20 - 60 bar [360 - 940 psi] Max inlet pressure 150 Bar
 B= 70 - 150 bar [960-2250 psi]
 C= 160 - 210 bar [2260-3120 psi]

Coil voltage

12D=12VDC
 24D=24VDC
 00=No Coil

Housing and ports

00 = Cartridge only
 6S = Al, #6 SAE
 8S = Al, #8 SAE
 SE3B = Al, 3/8" BSP
 SE4B = Al, 1/2" BSP
 Other housing available

Housing Nomenclature

No Body
 CP10-3-6S
 CP10-3-8S
 SDC10-3-SE3B
 SDC10-3-SE4B

Seals

B = Buna-N
 V = Viton

Seals kit

354004210
 354003719

Coil termination

00 = No coil, nut included
 AJ= AMP Junior
 DE= Deutsch
 DN= DIN 46650
 FL= Flying leads(140mm lead length standard)

P104 898



Cartridge Valves Technical Information

Proportional valves

PSV10-34-02



OPERATION

This is a non-compensated proportional directional control valve.

SPECIFICATIONS

Specifications

Rated pressure	250 bar [3600 psi]
Rated flow at 10 bar [150 psi]	22 l/min [6 US gal/min]
Weight	0.77 kg [1.70 lb]
Hysteresis	4% maximum
Threshold current	0.5 A (12 VDC coil) 0.25 A (24 VDC coil)
Maximum control current	1.5 A (12 VDC coil) 0.8 A (24 VDC coil)
Cavity	SDC10-4
Standard Coil	M16 26 Watt

Theoretical performance

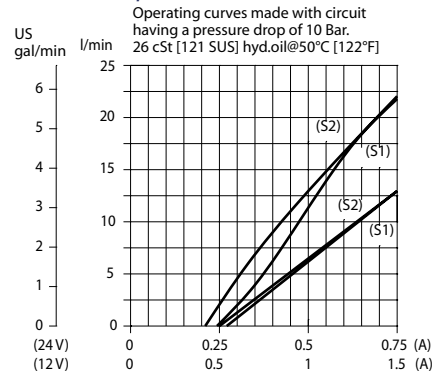

Schematic

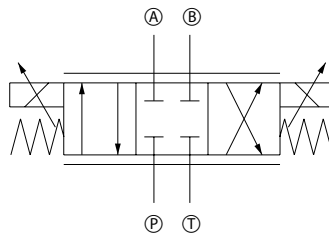

P102 711

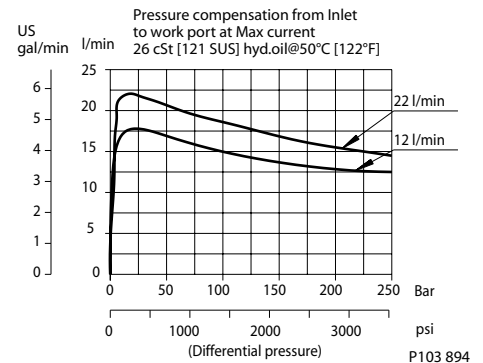

P103 894

DIMENSIONS

mm [in]

Cross-sectional view

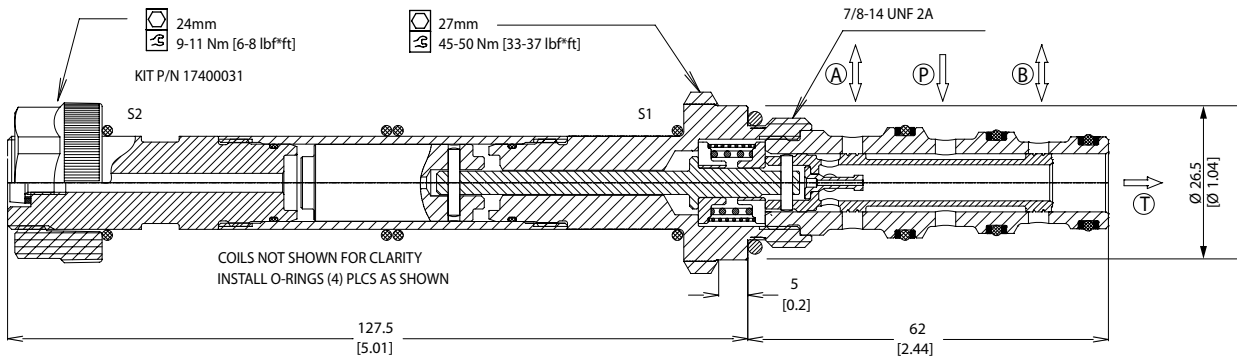

P103 824

ORDERING INFORMATION

PSV10-34-02-12-DN-22-B-XX

Coil voltage
0 = No coil
12 = 12V DC
24 = 24V DC

Coil termination
0 = No connector
AJ = Amp junior
AS = Amp superseal 1.5
DE = Deutsch
DN = DIN 43650
FL = Lead wires
SP = Spade

Housing and ports
00 = No Housing
L3B = AL, 3/8 BSP
L4B = AL, 1/2 BSP
6S = AL, #6 SAE
8S = AL, #8 SAE
Other housings available

Seals Seal Kit
B = Buna-N 35400191
V = Viton 35400201

Max regulated flow
12 = 12 l/min [3.2 gal/min]
22 = 22 l/min [5.8 gal/min]

Housing P/N
No Housing
SDC10-4-L-3B
SDC10-4-L-4B
CP10-4-6S
CP10-4-8S

P103 826E

Proportional valves
 P-DCV03-3Z11

OPERATION

This valve is a proportional directional control.

SPECIFICATIONS

Specifications

Rated pressure	320 bar [4640 psi]
Rated flow at 10 bar [145 psi]	30 l/min [8 US gal/min]
Weight	2.40 kg [5.29 lb]
Hysteresis	6% maximum
Threshold current	0.5 A (12 VDC coil) 0.25 A (24 VDC coil)
Maximum control current	2.4 A (12 VDC coil) 1.2 A (24 VDC coil)
Cavity	ISO D03
Standard Coil	PD03 40 Watt
Coil nut	158-8005

Theoretical performance

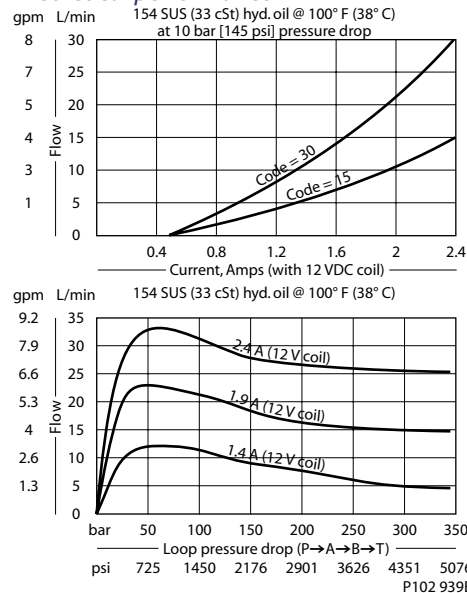

Schematic

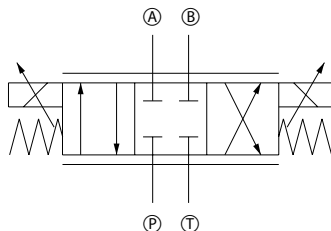

P102 711

DIMENSIONS

mm [in]

Cross-sectional view

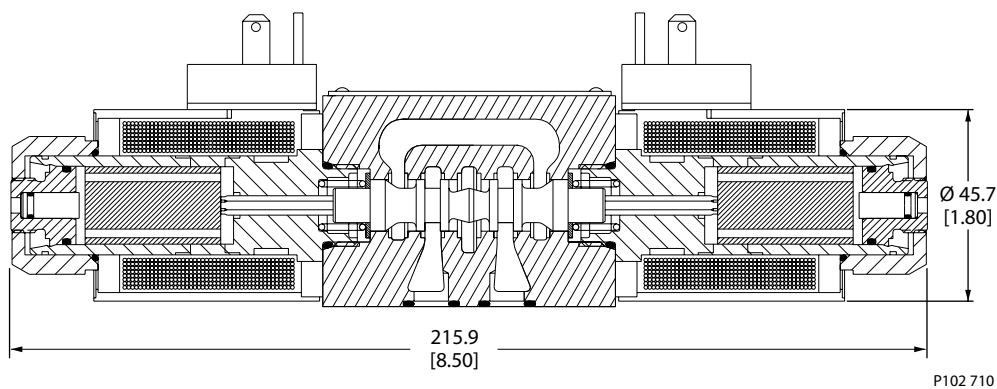

P102 710

ORDERING INFORMATION

PDCV03-3Z11/15-12-E1-8S

Subplate option

- OMIT = No subplate
- 8S = Aluminum, #8 SAE ports
- S8S = Steel, #8 SAE ports

Voltage

- 12 = 12 VDC
- 24 = 24 VDC

Nominal flow rate

- 15 = 15 L/min [4.0 gpm]
- 30 = 30 L/min [7.9 gpm]

Termination

- E1 = DIN 43650
- E3 = Amp Jr.
- E8 = Lead wires
- E12 = Deutsch
- E14 = Dual spade

Seal Kit

- B = Buna-N Seal kit 158-8007
 - V = Viton Seal kit 158-8062
- Note : All internal seals are viton

Bolt Kit

- #10-24 Thd. 158-8064
- M5 Thd. 158-8026

P102 714E



Cartridge Valves Technical Information

Proportional valves

P-DCV05-3Z11



OPERATION

This is a non-compensated proportional directional control valve.

SPECIFICATIONS

Specifications

Rated pressure	320 bar [4600 psi]
Rated flow at 10 bar [150 psi]	60 l/min [16 US gal/min]
Weight	6.60 kg [14.60 lb]
Hysteresis	6% maximum
Threshold current	0.2 A (12 VDC coil) 0.1 A (24 VDC coil)
Maximum control current	1.8 A (12 VDC coil) 0.9 A (24 VDC coil)
Cavity	ISO D05
Standard Coil	PD05 23 Watt

Theoretical performance

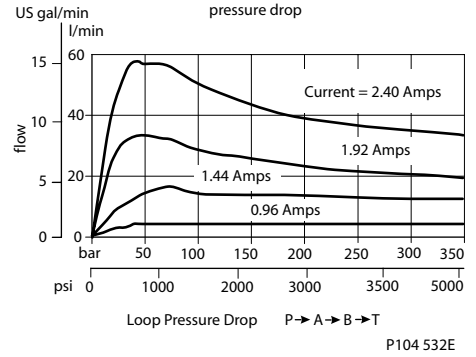
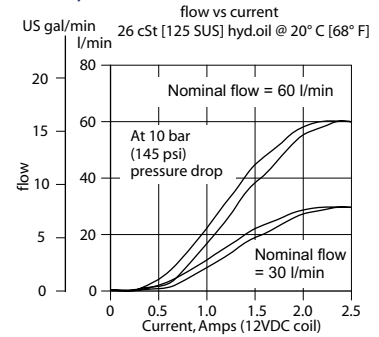

Schematic

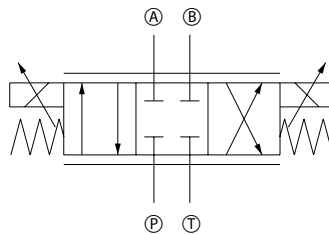

P102 711

DIMENSIONS

mm [in]

Cross-sectional view

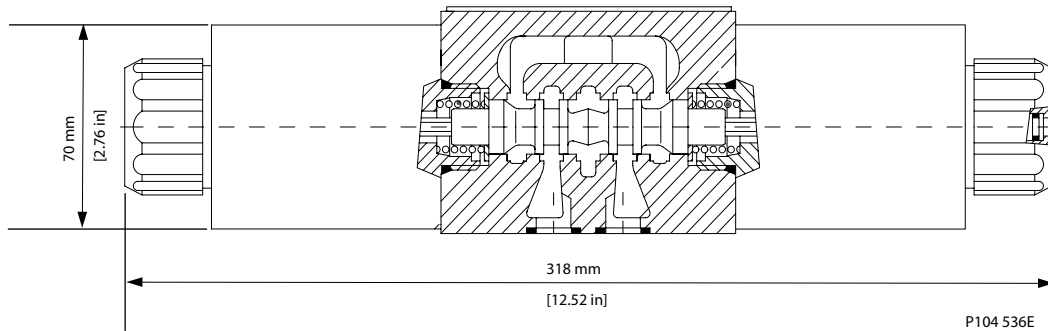

P104 536E

ORDERING INFORMATION

PDCV05-3Z11/30-12-E1

Connector

- E1 = DIN 43650
- E8 = Lead wires
- E10 = Deutsch on leads

Seal kit

- B = Buna N 158-8023
- V = Viton 158-8094
- All internal seals are Viton

Flow rate

- 30 = 30 l/min [7.9 US gal/min]
- 60 = 60 l/min [15.8 US gal/min]

Voltage

- 12 = 12 VDC
- 24 = 24 VDC

Bolt kit

- 1/4-20 Thd 158-8095
- M6 Thd 158-8024

P103 987E

Proportional valves
PSV10-34-05

OPERATION

This is a non-compensated proportional directional control valve.

SPECIFICATIONS

Specifications

Rated pressure	250 bar [3600 psi]
Rated flow at 10 bar [150 psi]	22 l/min [6 US gal/min]
Weight	0.77 kg [1.70 lb]
Hysteresis	4% maximum
Threshold current	0.5 A (12 VDC coil) 0.25 A (24 VDC coil)
Maximum control current	1.5 A (12 VDC coil) 0.8 A (24 VDC coil)
Cavity	SDC10-4
Standard Coil	M16 26 Watt

Theoretical performance

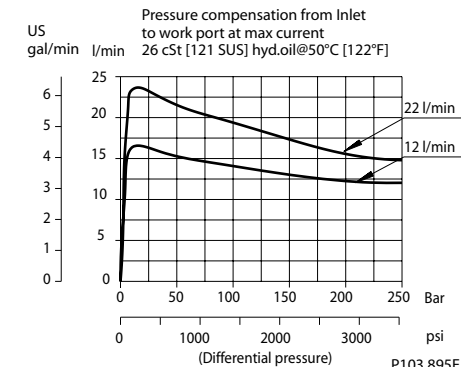
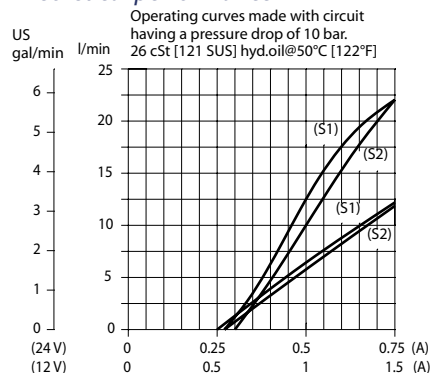

Schematic

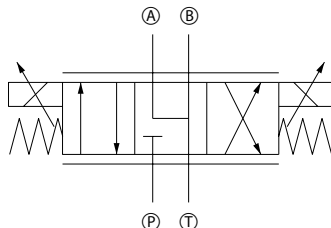

P102 712

DIMENSIONS

mm [in.]

Cross-sectional view

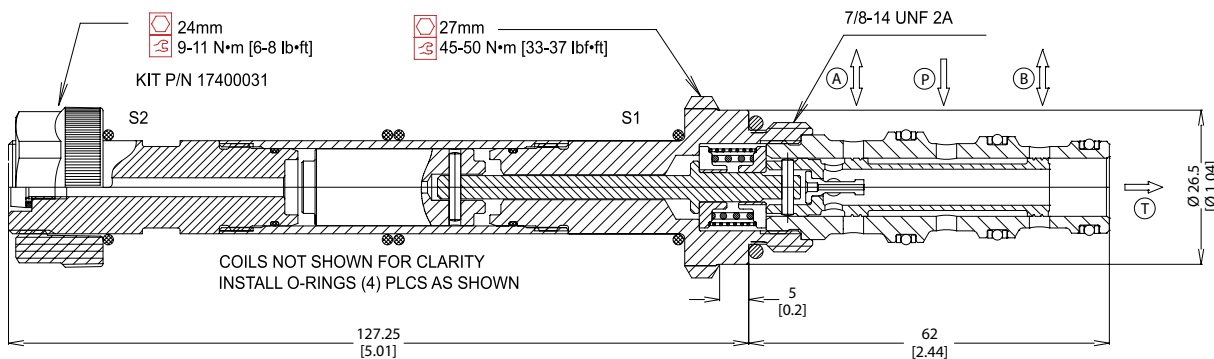

P103 825

ORDERING INFORMATION

PSV10-34-05-12-DN-22-B-XX

Coil voltage
 0 = No coil
 12 = 12V DC
 24 = 24V DC

Coil termination
 0 = No connector
 AJ = Amp junior
 AS = Amp superseal 1.5
 DE = Deutsch
 DN = DIN 43650
 FL = Lead wires
 SP = Spade

Housing and ports
 00 = No Housing
 L3B = AL, 3/8 BSP
 L4B = AL, 1/2 BSP
 6S = AL, #6 SAE
 8S = AL, #8 SAE
 Other housings available

Seals Seal Kit
 B = Buna-N 35400191
 V = Viton 35400201

Max regulated flow
 12 = 12 l/min [3.2 gal/min]
 22 = 22 l/min [5.8 gal/min]

Housing P/N
 No Housing
 SDC10-4-L-3B
 SDC10-4-L-4B
 CP10-4-6S
 CP10-4-8S

P103 827E



Cartridge Valves Technical Information

Proportional valves

P-DCV03-3Y11



OPERATION

This valve is a proportional directional control.

SPECIFICATIONS

Specifications

Rated pressure	320 bar [4640 psi]
Rated flow at 10 bar [145 psi]	30 l/min [8 US gal/min]
Weight	2.40 kg [5.29 lb]
Hysteresis	6% maximum
Threshold current	0.5 A (12 VDC coil) 0.25 A (24 VDC coil)
Maximum control current	2.4 A (12 VDC coil) 1.2 A (24 VDC coil)
Cavity	ISO D03
Standard Coil	PD03 40 Watt
Coil nut	158-8005

Theoretical performance

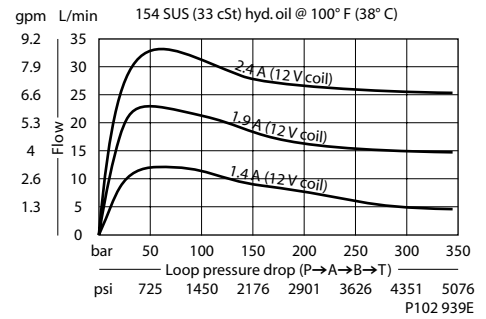
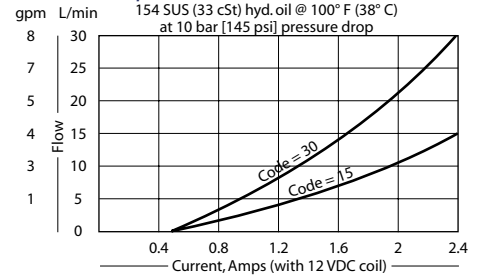

Schematic

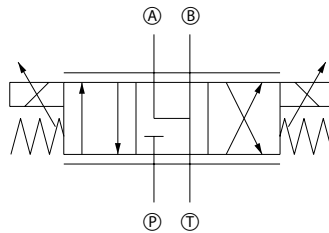

P102 712

DIMENSIONS

mm [in]

Cross-sectional view

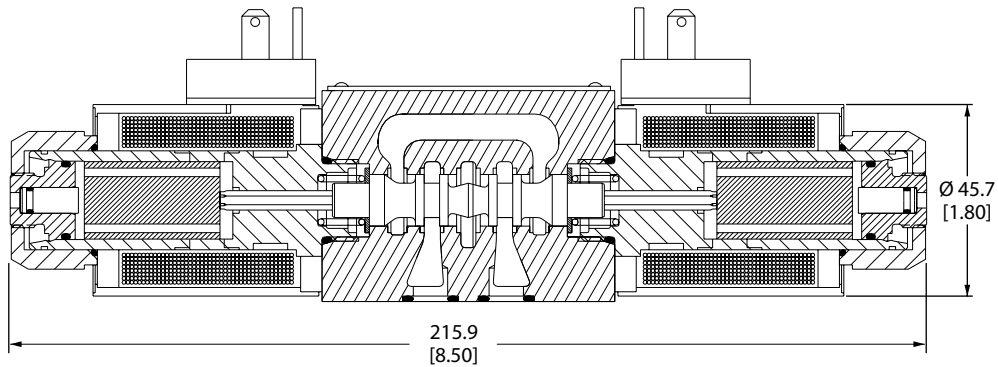

P102 710

ORDERING INFORMATION

PDCV03-3Y11/15-12-E1-8S

Subplate option

- OMIT = No subplate
- 8S = Aluminum, #8 SAE ports
- S8S = Steel, #8 SAE ports

Voltage

- 12 = 12 VDC
- 24 = 24 VDC

Nominal flow rate

- 15 = 15 L/min [4.0 gpm]
- 30 = 30 L/min [7.9 gpm]

Termination

- E1 = DIN 43650
- E3 = Amp Jr.
- E8 = Lead wires
- E12 = Deutsch
- E14 = Dual spade

Seal Kit

- Seal kit
- B = Buna-N 158-8007
- V = Viton 158-80062
- Note : All internal seals are viton

Bolt Kit

- #10-24 Thd. 158-8064
- M5 Thd. 158-8026

P102 713E



Cartridge Valves Technical Information

Proportional valves

P-DCV05-3Y11



Proportional valves
P-DCV05-3Y11

OPERATION

This is a non-compensated proportional directional control valve.

SPECIFICATIONS

Specifications

Rated pressure	320 bar [4600 psi]
Rated flow at 10 bar [150 psi]	60 l/min [16 US gal/min]
Weight	6.60 kg [14.60 lb]
Hysteresis	6% maximum
Threshold current	0.2 A (12 VDC coil) 0.1 A (24 VDC coil)
Maximum control current	1.8 A (12 VDC coil) 0.9 A (24 VDC coil)
Cavity	ISO D05
Standard Coil	PD05 23 Watt

Theoretical performance

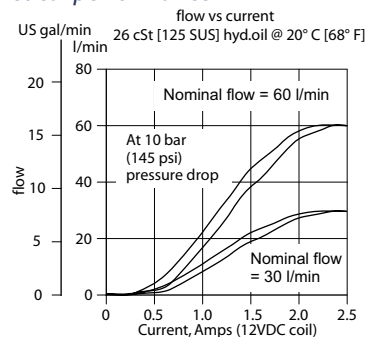

Schematic

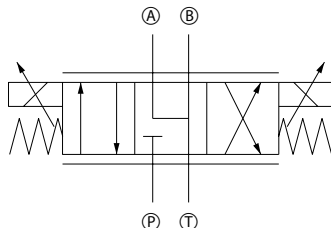

P102 712

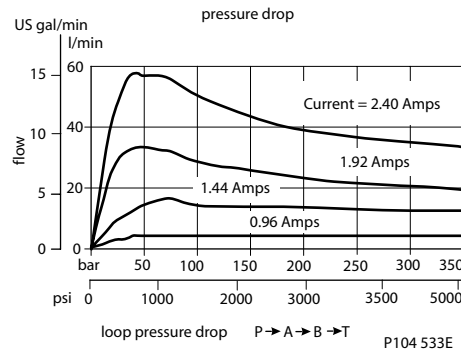

DIMENSIONS

mm [in]

Cross-sectional view

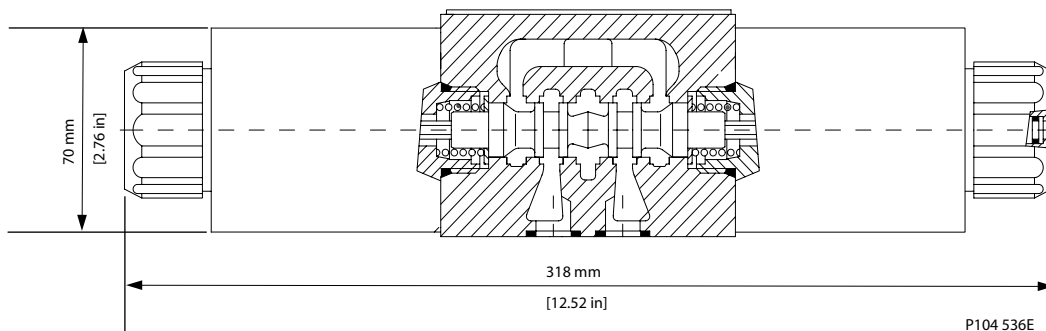

P104 536E

ORDERING INFORMATION

P-DCV05-3Y11/30-12-E1

- | | | | |
|---------------------------------|----------------|------------------------|------------------------------|
| Nominal flow rate | Voltage | Connector | Seal kit |
| 30 = 30 l/min [7.9 US gal/min] | 12 = 12 VDC | E1 = DIN 43650 | B = Buna N 158-8023 |
| 60 = 60 l/min [15.8 US gal/min] | 24 = 24 VDC | E8 = Lead wires | V = Viton 158-8094 |
| | | E10 = Deutsch on leads | All internal seals are Viton |
| | | Bolt kit | |
| | | 1/4-20 Thd 158-8093 | |
| | | M6 Thd 158-8024 | |

P103 986E