

SV16-23 Poppet, 2-Way, Normally Open

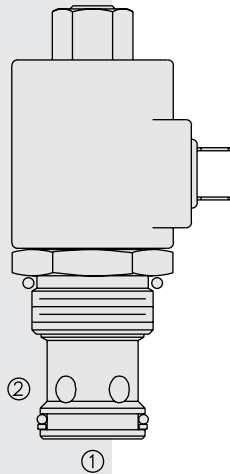

SYMBOLS

USASI:

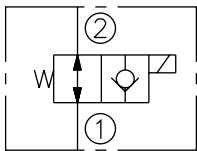

ISO:

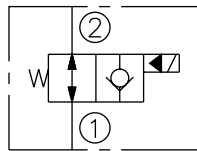

PERFORMANCE (Cartridge Only)

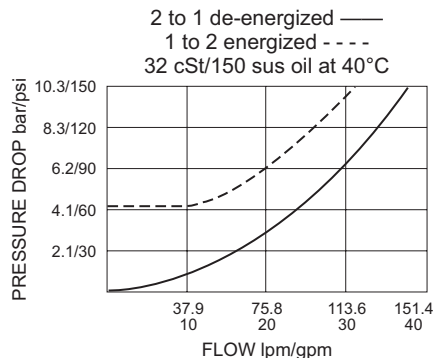

DESCRIPTION

A solenoid-operated, two-way, normally open, poppet-type, screw-in hydraulic cartridge valve, designed to function as a load holding or blocking valve in applications requiring low internal leakage.

OPERATION

When de-energized, the **SV16-23** poppet lifts to open the 2 to 1 flow path. In this mode, flow from 1 to 2 is also allowed.

When energized, the cartridge acts as a check valve, allowing flow to pass from 1 to 2, while blocking flow in the reverse direction after overcoming the solenoid force (requires 3.4 to 10.3 bar / 50 to 150 psi).

Operation of Manual Override Option: To override, push and hold override button.

FEATURES

- Continuous-duty rated solenoid.
- Hardened seat for long life and low leakage.
- Optional coil voltages and terminations.
- Efficient wet-armature construction.
- Cartridges are voltage interchangeable.
- Manual override option.
- Optional waterproof E-Coils rated up to IP69K.
- Unitized, molded coil design.
- Industry common cavity.

RATINGS

Operating Pressure: 207 bar (3000 psi); Under certain operating conditions, this valve may be used at higher pressures; consult factory.

Proof Pressure: 390 bar (5700 psi)

Flow: See Performance Chart

Internal Leakage: 0.15 cc/minute (3 drops/minute) max. at 207 bar (3000 psi)

Temperature: -40 to 120°C with standard Buna seals

Coil Duty Rating: Continuous from 85% to 115% of nominal voltage

Initial Coil Current Draw at 20°C: Standard Coil: 1.67 amps at 12 VDC;

0.18 amps at 115 VAC (full wave rectified).

E-Coil: 1.7 amps at 12 VDC; 0.85 amps at 24 VDC

Minimum Pull-in Voltage: 85% of nominal at 207 bar (3000 psi)

Filtration: See page 9.010.1

Fluids: Mineral-based or synthetics with lubricating properties at viscosities of 7.4 to 420 cSt (50 to 2000 sus); See Temperature and Oil Viscosity, page 9.060.1

Installation: No restrictions; See page 9.020.1

Cavity: VC16-2; See page 9.116.1

Cavity Tool: CT16-2XX; See page 8.600.1

Seal Kit: SK16-2X-T; See page 8.650.1

Coil Nut: Part No. 7004420;

For E-coils manufactured prior to 1-1-04, see page 3.400.1 for coil nut info.

DIMENSIONS

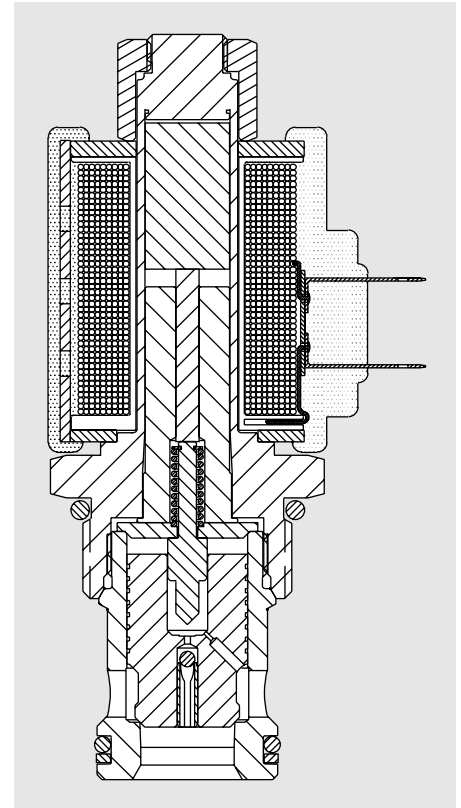
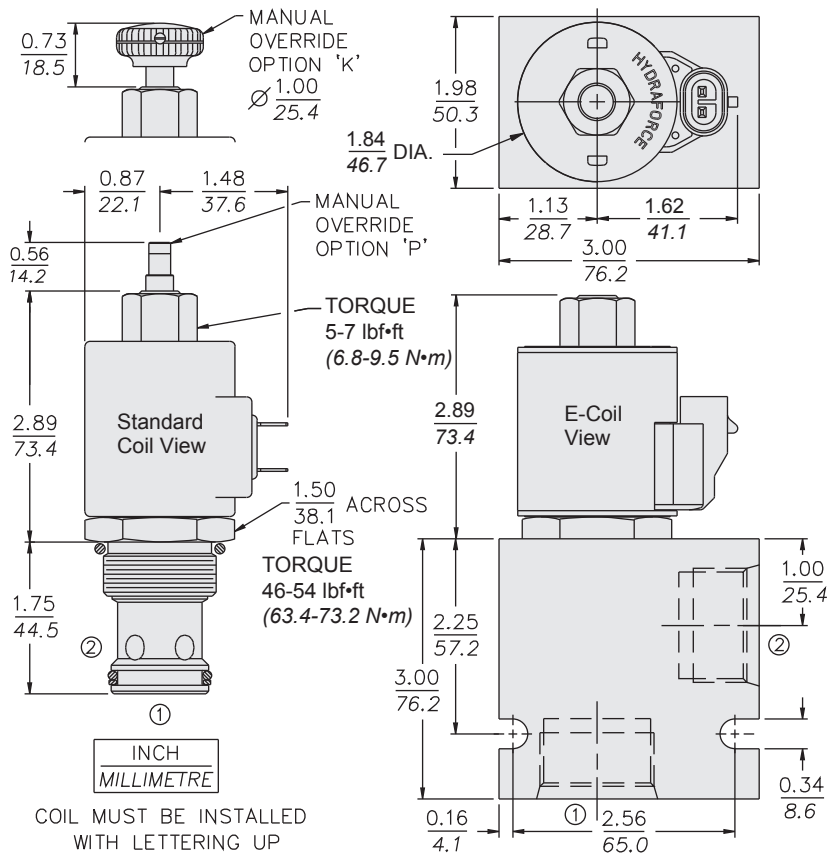

MATERIALS

Cartridge: Weight: 0.31 kg. (0.69 lbs.) Steel with hardened work surfaces. Zinc-plated exposed surfaces. Buna N O-rings and polyester elastomer back-up standard.

Standard Ported Body: Weight: 0.57 kg. (1.25 lbs.) Anodized high-strength 6061 T6 aluminum alloy, rated to 207 bar (3000 psi). Ductile iron bodies available; dimensions may differ. See page 8.016.1

Standard Coil: Weight: 0.27 kg. (0.60 lbs.) Unitized thermoplastic encapsulated, Class H high temperature magnetwire. See page 3.200.1

E-Coil: Weight: 0.41 kg. (0.9 lbs.) Fully encapsulated with rugged external metal shell. Rated up to IP69K with integral connectors. **Note: See page 3.400.1 for all E-Coil retrofit applications.**

TO ORDER

SV16-23

Option	None (Blank)
Manual Override without knob	P
Manual Override with knob	K
For Manual Override options see page 1.001.1	
Porting	
Cartridge Only	0
SAE 16	16T
Seals	
Buna N (Std.)	N
Fluorocarbon	V

Voltage	
Std. Coil	
0	Less Coil**
10	10 VDC†
12	12 VDC
24	24 VDC
36	36 VDC
48	48 VDC
24	24 VAC
115	115 VAC
230	230 VAC
**Includes Std. Coil Nut	
† DS, DW or DL terminations only.	
E-Coil	
10	10 VDC
12	12 VDC
20	20 VDC
24	24 VDC

Termination (VDC) Std. Coil	
DS	Dual Spades
DG	DIN 43650
DL	Leadwires (2)
DL/W	Leads w/Weatherpak® Connectors
DR	Deutsch DT04-2P
Termination (VAC) Std. Coil	
AG	DIN 43650
AP	1/2 in. Conduit
Termination (VDC) E-Coil	
ER	Deutsch DT04-2P (IP69K Rated)
EY	Metri-Pack® 150 (IP69K Rated)

Coils with internal diode are available. Consult factory.