

SV08-47D Spool, 4-Way, 3-Position, "Motor Spool"

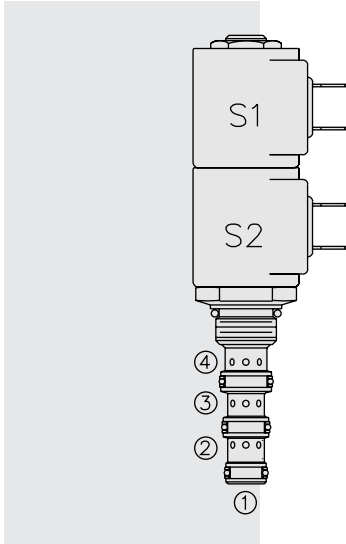

DESCRIPTION

A solenoid-operated, 4-way, 3-position, direct-acting, spool-type, motor spool, screw-in hydraulic cartridge valve.

OPERATION

When de-energized, the **SV08-47D** blocks flow to 3, while allowing flow from 2 to 1, and from 4 to 1. When coil #1 is energized, flow is allowed from 2 to 1, and from 4 to 1. When coil #2 is energized, flow is allowed from 3 to 2, and from 4 to 1.

In circuits where work port flows are unequal due to cylinder ratios, the higher return flow should be directed to port 2.

While 1 may be fully pressurized, it is not intended for use as the valve's inlet.
Operation of Manual Override Option: To override, push the knurled button to activate the coil #2 (S2) function, or pull the knob to activate the coil #1 (S1) function.

FEATURES

- Continuous-duty rated solenoid.
- Hardened precision spool and cage for long life.
- Optional coil voltages and terminations.
- Efficient wet-armature construction.
- All ports may be fully pressurized.
- Cartridges are voltage interchangeable.
- Unitized, molded coil design.
- Compact size.
- Optional waterproof E-Coils rated up to IP69K.
- Manual override option.

RATINGS

Operating Pressure: 207 bar (3000 psi)

Flow: 11.4 lpm (3 gpm) max.

Internal Leakage: 164 cc/minute (10 cu. in./minute) max. at 207 bar (3000 psi)

Temperature: -40 to 120 °C with standard Buna seals

Coil Duty Rating: Continuous from 85% to 115% of nominal voltage

Initial Coil Current Draw at 20 °C: Standard Coil: 1.2 A at 12 Vdc;
 0.13 A at 115 Vac (full wave rectified).

E-Coil: 1.4 A at 12 Vdc; 0.7 A at 24 Vdc

Minimum Pull-in Voltage: 85% of nominal at 207 bar (3000 psi)

Filtration: See page 9.010.1

Fluids: Mineral-based or synthetics with lubricating properties at viscosities of 7.4 to 420 cSt (50 to 2000 sus); See Temperature and Oil Viscosity, page 9.060.1

Installation: No restrictions; See page 9.020.1

Cavity: VC08-4; See page 9.108.1

Cavity Tool: CT08-4XX; See page 8.600.1

Seal Kit: SK08-4X-MMM; See page 8.650.1

Coil Nut: Part No. 7004400; **Manual Override Coil Nut:** Part No. 4528180;

Coil Spacer: Std D-Coil Spacer Part No. 7012940; E-Coil Spacer Part No. 4534720;
 If cartridge is ordered "Less Coil," D-Coil spacer will be provided unless an E is specified in the Coil Termination To Order section.

SYMBOLS

USASI:

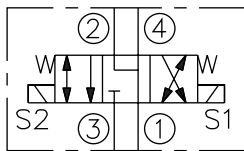

ISO:

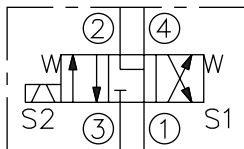

PERFORMANCE (Cartridge Only)

3 to 2, 3 to 4, 4 to 1: —
 2 to 1: - - -
 32 cSt/150 sus oil at 40 °C

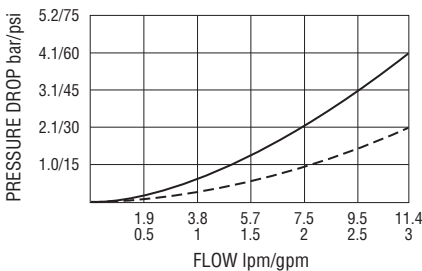

SV08-47D

DIMENSIONS

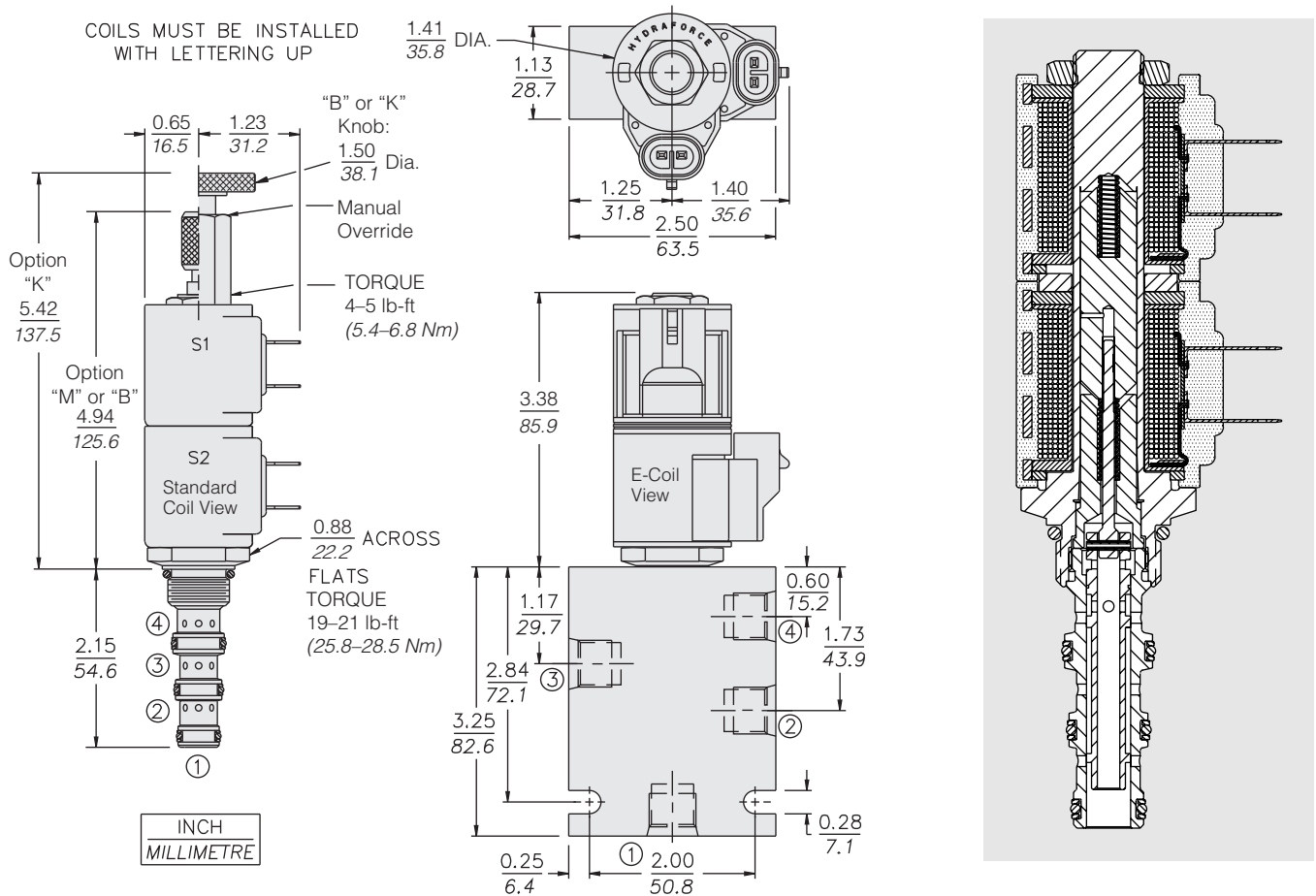

MATERIALS

Cartridge: Weight: 0.13 kg (0.28 lb); Steel with hardened work surfaces. Zinc-plated exposed surfaces; Buna N O-rings and back-ups standard.

Standard Ported Body: Weight: 0.27 kg (0.60 lb); Anodized high-strength 6061 T6 aluminum alloy, rated to 207 bar (3000 psi); Ductile iron bodies available; dimensions may differ. See page 8.008.1.

Standard Coil: Weight each: 0.11 kg (0.25 lb); Unitized thermoplastic encapsulated, Class H high temperature magnet wire. See page 3.200.1

E-Coil: Weight: 0.14 kg (0.3 lb); Perfect wound, fully encapsulated with rugged external metal shell; Rated up to IP69K with integral connectors. See page 3.400.1

TO ORDER

