

RV10-26 Relief, Pilot-Operated Spool

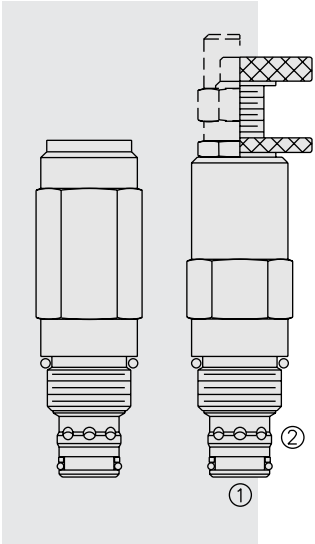

DESCRIPTION

A screw-in, cartridge-style, pilot-operated (two-stage), spool-type hydraulic relief valve, intended for use as a pressure limiting device in demanding hydraulic circuits which require fast response and low hysteresis.

OPERATION

The **RV10-26** blocks flow from ① to ② until sufficient pressure is present at ① to force the piloting relief off its seat, allowing the main (second stage) spool to shift, opening ① to ②.

The cartridge offers smooth transition in response to load changes in demanding hydraulic circuits.

NOTE: The RV10-26 cannot be used in crossover relief applications.

FEATURES

- Adjustments cannot be backed out of the valve.
- Adjustments prohibit springs from going solid.
- Hardened spool and cage for long life.
- Optional spring ranges to 210 bar (3000 psi).
- Fast, smooth response to pressure surges.
- Industry common cavity.

RATINGS

Operating Pressure: 240 bar (3500 psi)

Flow: The Performance Chart illustrates flow handling capacity at maximum setting for each spring range option. Pressure rise will vary with spring (range) and with setting within range due to flow forces. Consult factory for specific flow characteristic values.

Internal Leakage: 115 cc/minute (7 cu. in./minute) max. to 85% of nominal setting

Crack Pressure Defined: bar (psi) evident at 7.6 lpm (2.0 gpm) attained

Reseat Pressure: Nominal 90% of crack pressure

Standard Spring Ranges:

6.9 to 27.6 bar (100 to 400 psi);

10.3 to 103.4 bar (150 to 1500 psi);

27.6 to 206.9 bar (400 to 3000 psi)

Temperature: -40 to 120°C

Filtration: See page 9.010.1

Fluids: Mineral-based or synthetics with lubricating properties at viscosities of 7.4 to 420 cSt (50 to 2000 sus); See Temperature and Oil Viscosity, page 9.060.1

Installation: No restrictions; See page 9.020.1

Cavity: VC10-2; See page 9.110.1

Cavity Tool: CT10-2XX; See page 8.600.1

Seal Kit: SK10-2N-B; See page 8.650.1

SYMBOLS

USAS/ISO:

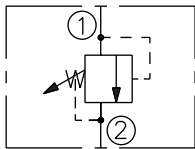

PERFORMANCE (Cartridge Only)

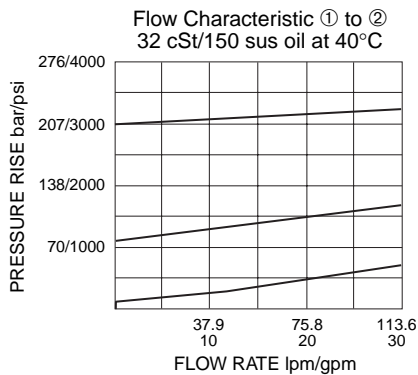

RV10-26

DIMENSIONS

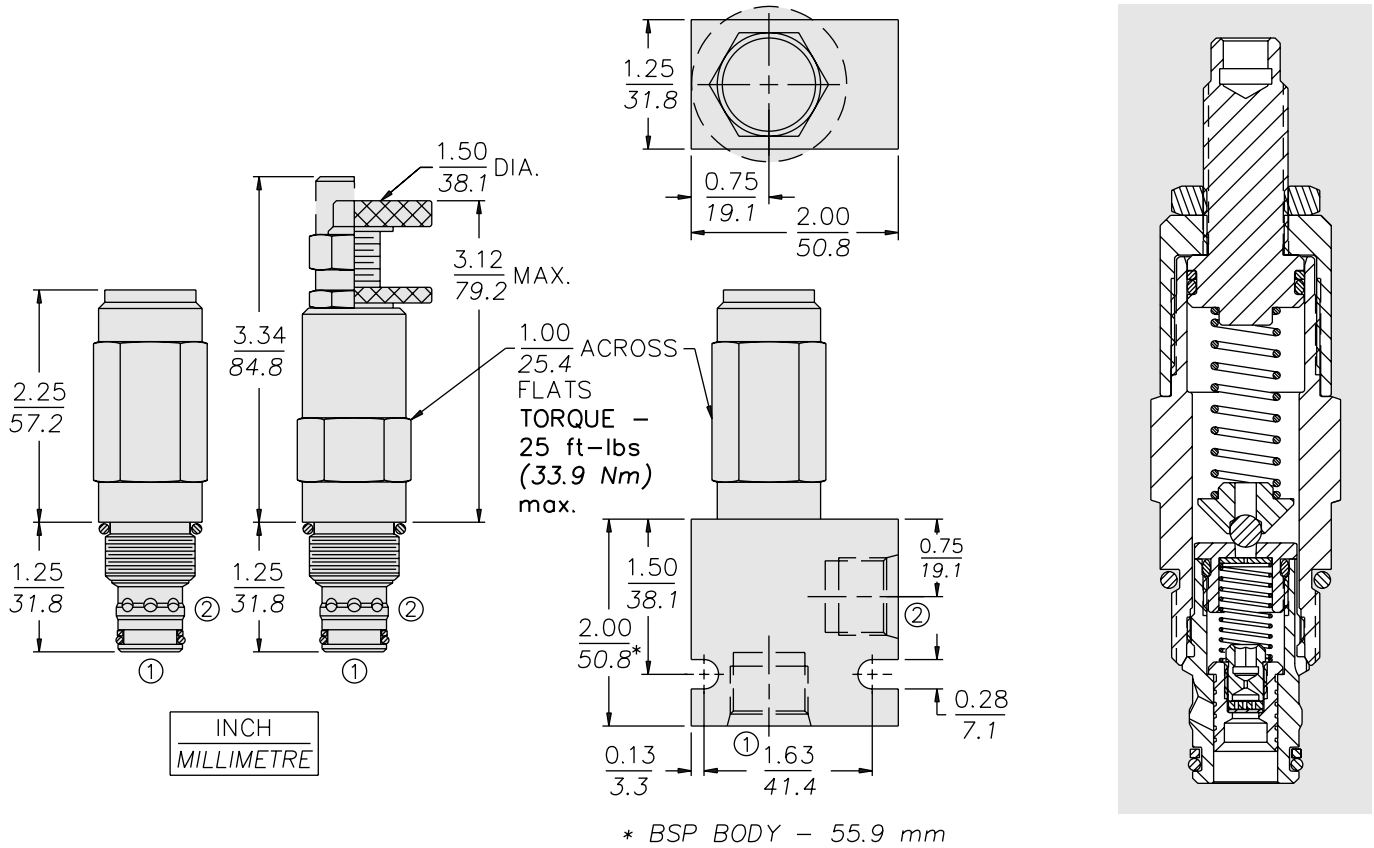

MATERIALS

Cartridge: Weight: 0.25 kg. (0.55 lbs.)
Steel with hardened work surfaces.
Zinc-plated exposed surfaces.
Buna N O-rings and polyester elastomer back-ups standard.
Anodized aluminum knobs.
Optional polyurethane seals with Fluorocarbon back-up recommended for pressures over 240 bar (3500 psi).

Standard Ported Body: Weight: 0.16 kg. (0.35 lbs.) Anodized high-strength 6061 T6 aluminum alloy, rated to 207 bar (3000 psi). Ductile iron bodies available; dimensions may differ. See page 8.010.1.

TO ORDER

RV10-26 - - - /

- Adjustment Option**
1/4 in. Hex Allen Head **A**
1-1/2 in. Dia. Alum. Knob **B**
Option A w/ Cover Cap **C**
Factory Preset Non-Adj. **F**
Factory Preset Hidden Adjustment **H**
Option C with Lockwire Holes **L**

- Porting**
Cartridge Only **0**
SAE 6 **6T**
SAE 8 **8T**
3/8 in. BSP* **3B**
1/2 in. BSP* **4B**

*BSP Body; U.K. Mfr. Only

- Seals**
Pressure on P Only:
N Buna N (Std.)
V Fluorocarbon

- Setting in bar†**
(Blank) for Adjustable, or Specify, for example:
M25 25 bar
M100 100 bar
Setting in psi†
(Blank) for Adjustable, or Specify, for example:
9.0 900 psi
23.5 2350 psi

- Spring Range**
4 6.9 to 27.6 bar (100 to 400 psi)
15 10.3 to 103.4 bar (150 to 1500 psi)
30 27.6 to 206.9 bar (400 to 3000 psi)

†Adjustable valves will be preset to approx. 50% of spring max. potential.