

Gasoline Pump

PG120-PG400 SERIES

130-400 cu. in./min.
Max. output gasoline
powered pumps.

Large reservoir capacity roll
cage equipped. PG120 for up
to 300 ton cylinders. PG400 for
up to 1,000 ton cylinders.

PUMPS

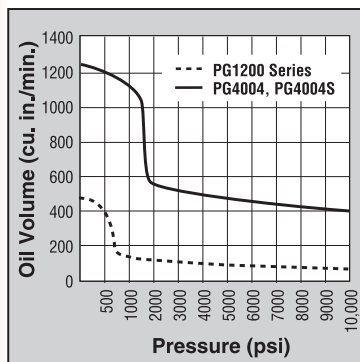

10,000 psi

- Two-speed high performance pumps ideal for construction, structure moving and rigging applications.
- A logical choice at work sites where electricity or compressed air are unavailable. For single- or double-acting cylinders at operating pressures to 10,000 psi.
- All gasoline engine/hydraulic pumps feature "Posi-Check" valve to guard against pressure loss when valve is shifted from "advance" to "hold".
- PG1200 Series pumps powered by a Honda 4-cycle, 5.5 hp engine with automatic decompression and electronic ignition. Deliver over ½ gallon (130 cu. in.) of oil per minute at 10,000 psi.
- A 5 gallon reservoir means adequate capacity for multi-cylinder applications. Dual element air cleaner protects engine from dusty environments.



PG4004S

- Heavy duty "roll cage" provides pick-up points for lifting. Horizontal bars on PG1203, PG1204 and PG1204S protect unit, provide hand holds for carrying.
- Rubber anti-skid insulation on bottom of reservoir resists skidding and dampens vibration. PG1200M-4 and PG1200M-4D include a pump cart with 12" wheels.
- Adjustable external pressure regulator.

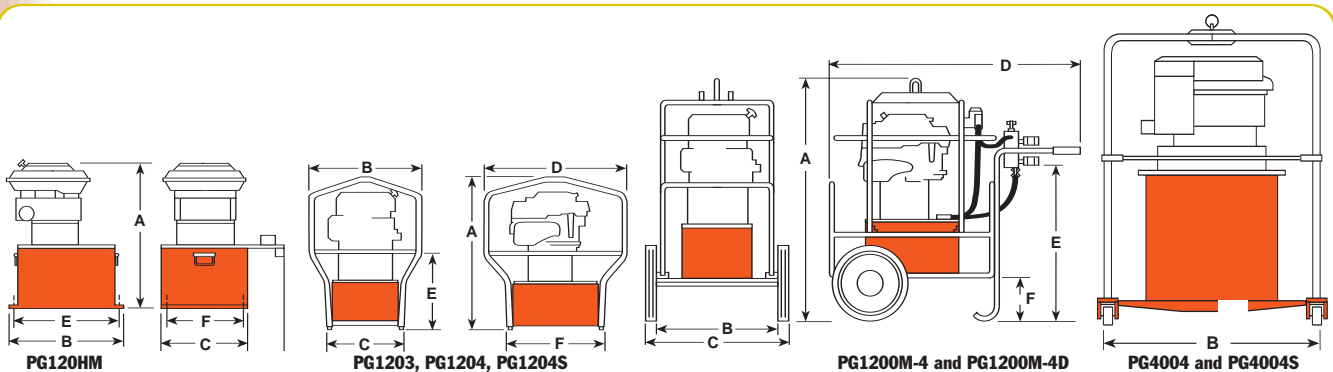

Pump No.	Max. Pressure Output (psi)	rpm	Oil Del. (cu. in./min. @)				A (in.)	B (in.)	C (in.)	D (in.)	E (in.)	F (in.)	Prod. Wt. w/Oil (lbs.)
			100 (psi)	1,000 (psi)	5,000 (psi)	10,000 (psi)							
PG120HM	10,000	3,600	480	175	150	130	23	15½	14¼	19	13 ⁵ / ₁₆	12 1/8	150
PG1203	10,000	3,600	480	175	150	130	27 ⁷ / ₈	20¼	14¼	26¼	13½	18¼	154
PG1204	10,000	3,600	480	175	150	130	27 ⁷ / ₈	20¼	14¼	26¼	13½	18¼	154
PG1204S	10,000	3,600	480	175	150	130	27 ⁷ / ₈	20¼	14¼	26¼	13½	18¼	161
PG1200M-4	10,000	3,600	480	175	150	130	42 ¹ / ₈	18	25	42½	26¼	7¼	260
PG1200M-4D	10,000	3,600	480	175	150	130	42 ¹ / ₈	18	25	42½	26¼	7¼	280
PG4004	10,000	3,600	1,240	1,120	475	400	50¼	52	52	—	—	—	435
PG4004S	10,000	3,600	1,240	1,120	475	400	50¼	52	52	—	—	—	440

PG1204S



(tandem center) valve, and second 4-port manifold without needle valves mounted beneath 9644 manifold for operating double-acting cylinders.

PG400 Series Maximum output Hydraulic Power Package

- Ideal for single or multiple cylinder applications. Has a 4-cycle, 20 hp Honda engine and 20 gallon reservoir (17 gallons usable) with low oil level sight gauge.
- Steel “roll cage” protects pump, has a lifting hook; 4" dia. swivel casters provide mobility.

PG1200M-4D



- Delivers 400 cu. in. of oil at maximum operating pressure.
- Has a 9506 4-way valve. On/off switch and speed control are protected by a panel. Sturdy molded case protects battery (not included).

PG1200M-4

- For single-acting cylinders. Has 9520 3-way/3-position (tandem center) valve, 9596 load lowering valve and 9644 4-port manifold with individual needle valves at each port.
- Has a 9796 coupler and 9797 dust cap at each port. Valving permits precise individual control of up to four cylinders.
- A 9052 heavy duty, fluid filled pressure gauge (0-10,000 psi) is included.

PG1200M-4D

- For single- or double-acting cylinders with precise individual control of up to four cylinders possible.
- Equipped same as PG1200M-4, except has 9506 4-way/3-position

For use with Cyl. Type	Description	Order No.	Valve Type	Valve No.	Valve Function	Usable (cu. in.)	Reservoir	
							Horsepower	Cycle
Single-Acting	Base model 5½ hp gasoline pump with 5.7 gal. reservoir.	PG1203	3-Way	9520	Advance Hold Return	1,300	5.5	4
Single-Acting	PG1203 with cart, rollcage, load lowering valve, 4 port manifold & gauge.	PG1200M-4	3-Way Manifold	9520 9644	Advance Hold Return**	1,300	5.5	4
Single-Acting/ Double-Acting	PG1200M-4D, except without “Roll Cage” and cart. Ideal for house moving industry.	PG120HM	4-Way Manifold	9506 9642	Advance Hold Return**	1,300	5.5	4
Double-Acting	Base model 5½ hp gasoline pump, with 5.7 gal. reservoir, roll cage and double-acting valve.	PG1204	4-Way	9506	Advance Hold Return	1,300	5.5	4
Double-Acting	PG1204, except has roll cage, solenoid valve and 25 ft. cord.	PG1204S	4-Way Solenoid***	9516	Advance Hold Return	1,300	5.5	4
Double-Acting	PG1200M-4, except for double-acting systems.	PG1200M-4D	4-Way Manifold	9506 9644	Advance Hold Return**	1,300	5.5	4
Double-Acting	Base model 20 hp pump with 20 gal. reservoir.	PG4004	4-Way	9506	Advance Hold Return	3,927	20	4
Double-Acting	PG4004, except has solenoid operated remote valve.	PG4004S	4-Way Solenoid***	9516	Advance Hold Return	3,927	20	4

* Usable oil is calculated with oil fill at recommended level at 2¼" below cover plate.

** Control up to 4 cylinders independently.

*** Has 25 ft. remote control cord.

