

# Electric Pump

## HYDRAULIC PE17 SERIES

Up to 55 Ton  
17 cu. in./min.  
2 Speed

For maintenance and construction applications.

- For use with single-acting or double-acting cylinders at operating pressures to 10,000 psi.
- For intermittent duty; starts under full load.
- Equipped with ½ hp, 3,450 rpm, single-phase, thermal protected induction motor; 10 ft. remote control cord (PE172S has 25 ft. cord)
- Low amperage draw; small generators and low amperage circuits can be used as power source.
- Extremely quiet noise level (67-81 dBA).



PE172

10,000 psi  
  
 LR19814

PUMPS

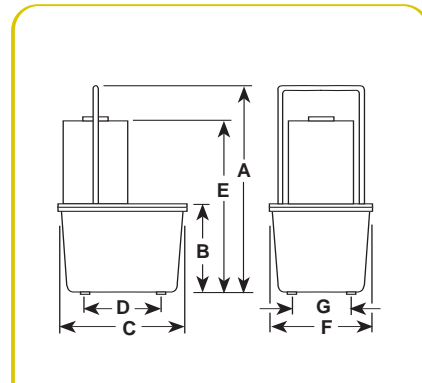
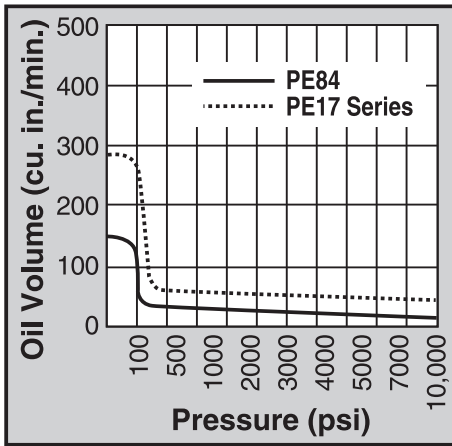

Pump No.	Max. Pressure Output		dBa at Idle and 10,000 (psi)	Amp Draw 115 V - at 10,000 (psi)	Oil Del. (cu. in./min. @) †				Dimensions							Prod. Wt. with Oil (lbs.)
	(psi)	rpm			0 (psi)	100 (psi)	5,000 (psi)	10,000 (psi)	A (in.)	B (in.)	C (in.)	D (in.)	E (in.)	F (in.)	G (in.)	
<b>PE17 Series</b>	10,000	3,450	67/81*	10	290	190	20	16	18½	7	11¾	7¼	14¾	9¼	5¼	45
<b>PE17M Series</b>	10,000	3,450	67/81*	10	290	190	20	16	18½	6⅝	11½	—	14½	9½	—	53

\* Measured at 3 ft. distance, all sides.  
 † Typical delivery. Actual flow will vary with field conditions.



For use with Cyl. Type	Description	Order No.	Valve Type	Valve No.	Valve Function	Control Switch ††	Motor	Reservoir Usable (cu. in.)
Single-Acting	Base model pump with 1/2 hp pump with 2 gal. thermoplastic reservoir.	<b>PE172</b>	2-Way	9517	Advance Return (Auto†)	Remote Motor Control (10ft.) on/off	1/2 hp, 110/115V* 50/60 Hz, Single Phase	295
Single-Acting	PE172, except has 2 1/2 gal. aluminum reservoir.	<b>PE172M</b>	2-Way	9517	Advance Return (Auto†)	Remote Motor Control (10ft.) on/off	1/2 hp, 110/115V* 50/60 Hz, Single Phase	375
Single-Acting	PE172, has solenoid operated valve.	<b>PE172S</b>	3-Way	9579	Advance Hold Return	Remote Motor & Valve (25 ft.)	1/2 hp, 110/115 VAC 50/60 Hz, Single Phase	295
Single-Acting	PE172S, except has aluminum reservoir.	<b>PE172SM</b>	3-Way	9579	Advance Hold Return	Remote Motor & Valve (25 ft.)	1/2 hp, 110/115 VAC 50/60 Hz, Single Phase	375
Single-Acting	Best suited for crimping, punching, pressing. Not for lifting. Thermoplastic reservoir.	<b>PE172A</b> ∞	Auto./Dump Manifold	45554	Advance Return	Remote Motor Control (10ft.) on/off	1/2 hp, 110/115V* 50/60 Hz, Single Phase	295
Single-Acting	PE172A, except has aluminum reservoir.	<b>PE172AM</b> ∞	Auto./Dump Manifold	45554	Advance Return	Remote Motor Control (10ft.) on/off	1/2 hp, 110/115V* 50/60 Hz, Single Phase	375
Single/ Double-Acting	PE172, except has 9500 double-acting valve.	<b>PE174</b>	4-Way	9500	Advance Hold Return**	Remote Motor Control (10ft.) on/off	1/2 hp, 110/115V* 50/60 Hz, Single Phase	295
Single/ Double-Acting	Same as PE174, except has aluminum reservoir.	<b>PE174M</b>	4-Way	9500	Advance Hold Return**	Remote Motor Control (10ft.) on/off	1/2 hp, 110/115V* 50/60 Hz, Single Phase	375

\* Available with 220 V., 50 Hz motor (to order, place suffix "50-220" behind pump order number).  
 \*\* "Advance" position holds pressure with motor shut off.  
 † "Advance" position holds pressure with motor shut off. "Return" position advances cylinder with motor running and returns cylinder with motor shut off.  
 †† Control switch on PE17 series wired with line voltage.  
 ∞ Not to be used for lifting.

**NOTE:** The remote motor control switch on 220V., 50 cycle PE17 series pumps is 24 volt.  
**NOTE:** Usable oil is calculated with the oil fill at the recommended level of 1 1/2" below reservoir cover plate.  
 ‡Some Power Team pumps are available in special configurations not listed in this catalog. Power Team can "Assemble to Order" pumps with special seals, voltages, valves, relief valve settings, etc. For your special requirements please consult your local distributor or the Power Team factory.

