

PC08-30 Check, Pilot-to-Open

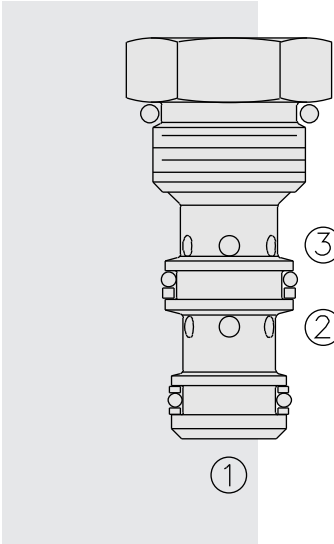

DESCRIPTION

A screw-in, cartridge-style, pilot-operated, hydraulic check valve for use in blocking or load-holding circuits.

OPERATION

The **PC08-30** allows flow from 2 to 3, while normally blocking flow from 3 to 2. Flow will be allowed from 3 to 2 when sufficient pressure is applied at 1.

The cartridge has a 3:1 pilot ratio, meaning that at least one-third of the load pressure held at 3 is required at 1 to open the valve.

The check is spring-biased to assure holding in static or no-load conditions. A sealed pilot piston option is available.

FEATURES

- Hardened seat for long life and low leakage.
- Optional sealed piston.
- Optional spring ranges.
- Compact size.

RATINGS

Operating Pressure: 240 bar (3500 psi)

Flow: See Performance Chart

Maximum Internal Leakage at 207 bar (3000 psi):

- 3 to 2: 0.10 ml/minute (2 drops/minute)
- 2 to 1 without sealed piston: 115 ml/minute (7 cu. in./minute)
- 2 to 1 with sealed piston: zero leakage

Pilot Ratio: 3:1

Check Spring Bias: 1.72 bar (25 psi) standard;
With sealed piston option: 6.2 bar (90 psi) minimum

Temperature: -40 to 100°C (-40 to 212°F) with standard Buna seals;
-26 to 204°C (-15 to 400°F) with fluorocarbon seals;
-54 to 107°C (-65 to 225°F) with polyurethane and urethane seals.

Filtration: See page 9.010.1

Fluids: Mineral-based or synthetics with lubricating properties at viscosities of 7.4 to 420 cSt (50 to 2000 sus); See Temperature and Oil Viscosity, page 9.060.1

Installation: No restrictions; See page 9.020.1

Cavity: VC08-3; See page 9.108.1

Cavity Tool: CT08-3XX; See page 8.600.1

Seal Kit: SK08-3X-TM; See page 8.650.1

ISO SYMBOL

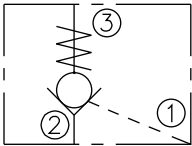

PERFORMANCE (Cartridge Only)

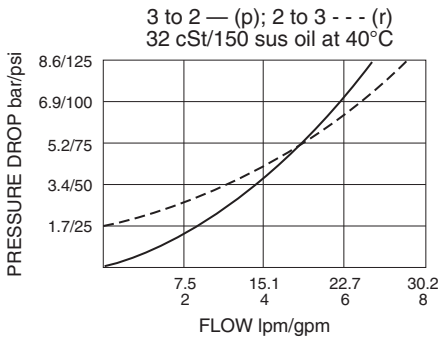

PC08-30

DIMENSIONS

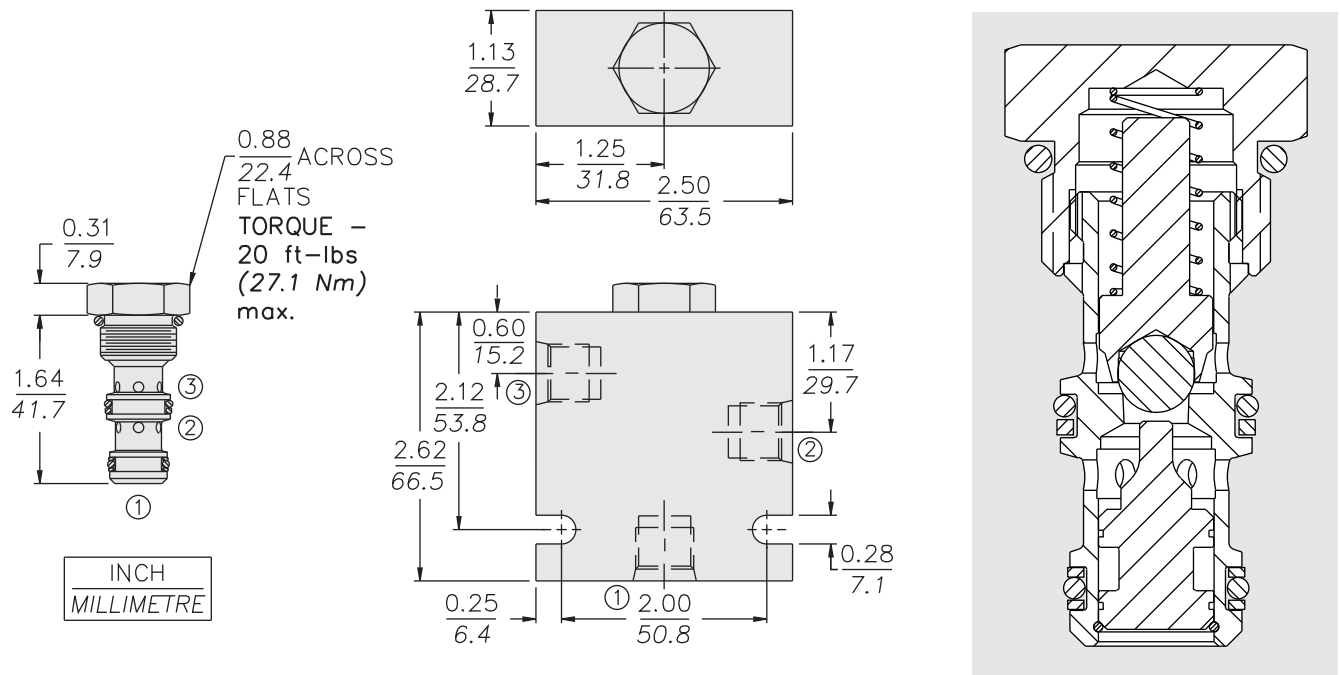

MATERIALS

Cartridge: Weight: 0.06 kg. (0.14 lbs.)
Steel with hardened work surfaces.
Zinc-plated exposed surfaces.
Buna N O-rings and back-ups
standard.

Standard Ported Body: Weight:
0.27 kg. (0.60 lbs.) Anodized high-
strength aluminum alloy, rated to 207
bar (3000 psi). Ductile iron bodies
available; dimensions may differ.
See page 8.008.1

TO ORDER

PC08-30

Options

None (Blank)

Porting

Cartridge Only **0**
SAE 4 **4T**
SAE 6 **6T**
3/8 in. BSP* **3B**

*BSP Body;
U.K. Mfr. Only

Bias Spring

(Blank) 1.72 bar/25 psi (Std.)*
70 4.8 bar/70 psi
90 6.2 bar/90 psi
120 8.2 bar/120 psi
270 18.3 bar/270 psi

Note: Other bias spring pressures available
for OEM applications. Consult factory.

* PC08-30 valves built with standard 25 psi
spring are not stamped with spring rating.
Other spring ratings are stamped on valve.

Seals

N Buna N (Std.)
NS Buna N with Sealed Piston
V Fluorocarbon
VS Fluorocarbon with Sealed Piston
P Polyurethane
PS Polyurethane with Sealed Piston
U Urethane
US Urethane with Sealed Piston

Note: NS, VS, US and PS seal options require
6.2 bar (90 psi) spring minimum.