

# Mechanical PUSH PULLERS

10, 17½, &  
30 Ton Cap.

For removing and installing gears, bearings, pulleys and other press-fitted parts.

Fed. Spec.: GGG-P-00781-D

- Can apply a pushing or pulling force, depending on how the puller is set up.
- Optional leg kits adapt your Push-Puller® to extra long or extra short reach.
- A wide variety of threaded adapters, bearing pulling attachments and internal pulling attachments can be used in combination with our Push-Pullers.®

**Selection and capacity rating** – Each Push-Puller's specified tonnage "capacity" is determined using its standard legs in tension. Using longer legs, or a setup in which the legs are in compression, will reduce the "capacity". Always select the largest "capacity" puller and the shortest legs that will fit the job.

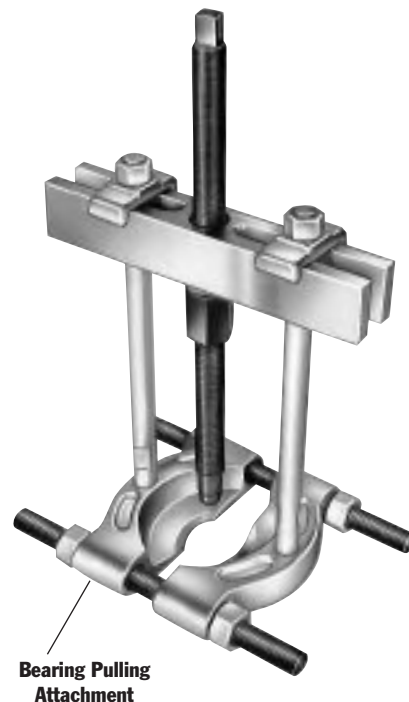

BEARING MAINTENANCE

## ASSEMBLING THE TOOL TO APPLY PUSHING OR PULLING FORCE:

1. Determine if you want the tool's forcing screw to push or pull.
2. To exert pushing force, the forcing nut is installed beneath the cross block, as shown on left.
3. To cause the forcing screw to pull, the forcing nut is placed on top of the cross block.
4. The sliding plates must always be placed on the opposite side of the cross block from the forcing nut.

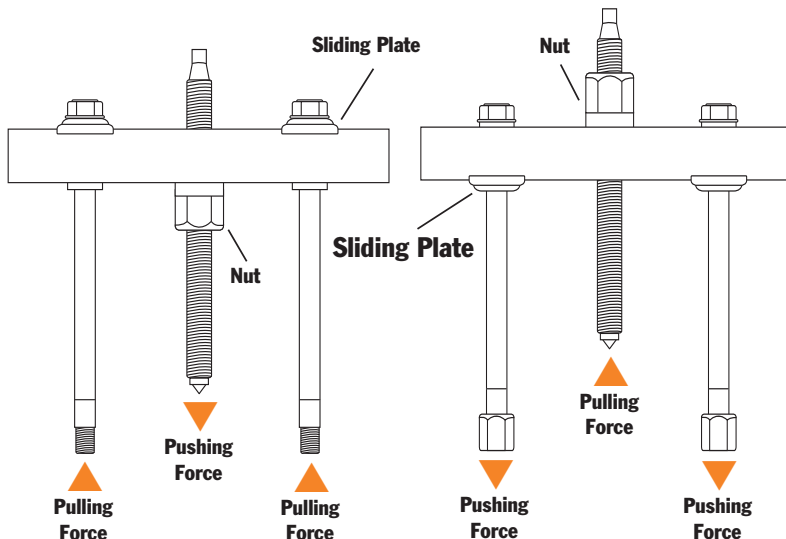

### Available Adapters (page 214-215)



Male/Female



Step Plate



Shaft Protector



Female

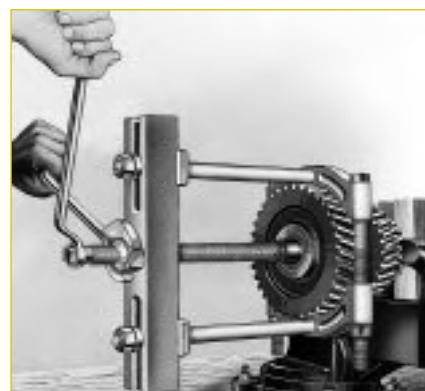













Internal Pulling Attachment





**No. 927 – 10-Ton Capacity** can be used with No. 1123 bearing pulling attachment or No. 679 pulley pulling attachment. May also be used with Nos. 1150, 1151, 1152, or 1153 internal pulling attachments.

**No. 938 – 17½-Ton Capacity** can be used with Nos. 1124 and 1130 bearing pulling attachments or Nos. 679 and 680 pulley pulling attachments. May also be used with Nos. 1150, 1151, 1153, 1165, or 1166 internal pulling attachments.

**No. 939 – 30-Ton Capacity** can be used with Nos. 1126 and 1127 bearing pulling attachments or No. 680 pulley pulling attachment (two 8012 adapters are required to connect 680 to puller). Can be used with No. 1165 internal pulling attachment.

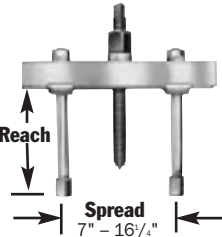
927		Max.				
	Reach	Spread	Screw	Size	Notes / Weight	
	8 <sup>3</sup> / <sub>4</sub> "	2 <sup>1</sup> / <sub>8</sub> " – 7 <sup>1</sup> / <sub>4</sub> "	¾"–16 x 12"		½" of forcing screw tip end is threaded 5/8"-18. No. 1100 legs and No. 24827 leg ends included. Wt., 7 lbs.	
<b>Order No.</b>	<b>Leg Length &amp; Wt.</b>			<b>Order No.</b>	<b>Leg Length &amp; Wt.</b>	
<b>1103</b>	4 <sup>3</sup> / <sub>4</sub> " 1 lb.			<b>1102</b>	11 <sup>3</sup> / <sub>4</sub> " 2 lbs., 4 oz. 	
<b>1100</b>	6 <sup>3</sup> / <sub>4</sub> " 1 lb., 8 oz.			<b>1101</b>	15 <sup>3</sup> / <sub>4</sub> " 3 lbs., 4 oz. 	
Extra Legs (pair) for No. 927 Push-Puller (Reach equals leg length plus 1½" with leg end caps.)						

938		Max.				
	Reach	Spread	Screw	Size	Notes / Weight	
	11 <sup>1</sup> / <sub>8</sub> "	3 <sup>1</sup> / <sub>8</sub> "–11 <sup>3</sup> / <sub>4</sub> "	1"–14 x 13 <sup>1</sup> / <sub>4</sub> "		Leg ends threaded 5/8"-18. No. Spread 1106 legs and No. 24827 leg ends included. Wt., 20 lbs., 12 oz.	
<b>Order No.</b>	<b>Leg Length &amp; Wt.</b>			<b>Order No.</b>	<b>Leg Length &amp; Wt.</b>	
<b>1107</b>	4.5" 2 lbs., 8 oz.			<b>1105</b>	22 <sup>1</sup> / <sub>2</sub> " 9 lbs. 	
<b>1106</b>	9 <sup>1</sup> / <sub>2</sub> " 4 lbs., 8 oz.			<b>1108</b>	30" 11 <sup>1</sup> / <sub>2</sub> lbs. 	
<b>1104</b>	16 <sup>1</sup> / <sub>2</sub> " 6 lbs., 8 oz.					
Extra Legs (pair) for No. 938 Push-Puller (Reach equals leg length plus 2" with leg end caps.)						

939		Max.				
	Reach	Spread	Screw	Size	Notes / Weight	
	10 <sup>1</sup> / <sub>2</sub> "	7"–16 <sup>1</sup> / <sub>4</sub> "	1 <sup>1</sup> / <sub>2</sub> "–12 x 17 <sup>1</sup> / <sub>4</sub> "		Leg ends threaded 1"–14. No. 1109 legs and No. 28390 leg ends included. Wt., 44 lbs.	
<b>Order No.</b>	<b>Leg Length &amp; Wt.</b>			<b>Order No.</b>	<b>Leg Length &amp; Wt.</b>	
<b>1109</b>	8" 8 lbs.			<b>1111</b>	28" 22 lbs. 	
<b>1110</b>	18" 15 lbs.					
Extra Legs (pair) for No. 939 Push-Puller (Reach equals leg length plus 2 <sup>5</sup> / <sub>8</sub> " with leg end caps.)						