

- Full off-center pressing at full rated capacity across width of upper frame without buckling or bending.
- Maximum "daylight" is 42" x 36", making positioning of even bulky work pieces easy.
- Height of press bed is easily adjusted with winch; friction brake prevents bed from dropping and handle from spinning upon release.
- Presses with single-acting cylinder offer choice of 2-speed hand operated, electric/hydraulic, or air/hydraulic pump. Models with double-acting cylinder have an electric/hydraulic pump.
- Press models equipped with remote control enable operator to view work from all sides with fingertip control of cylinder piston travel.
- Press can be used horizontally for special applications with user-supplied support legs.

Press H FRAME

55 Ton Presses



Hydraulic gauge and hydraulic fittings are included with presses.

PUMP ELECTRICAL SPECIFICATIONS

PE17 Series – 1/2 hp, 115 volt, 60 cycle, single phase. Also available in 230 volt, 50 cycle.

PE21 Series – 1 hp, 115 volt, 60 cycle, single phase. Also available in 230 volt, 50 cycle.

PQ60 Series – 2 hp, 230 volt, 60 cycle, single phase. Also available in 230 volt, 50 cycle. To order presses with 230 volt, 50 cycle pumps, add suffix "-220" to order no.



No. SF50 – Straightening fixtures for use with 55-ton shop or 80-ton Roll-Bed® presses (2 ea.). Wt., 104 lbs. **Not part of press, order separately.**

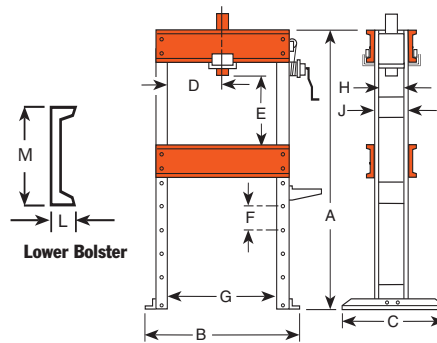

DIMENSIONS

A (in.)	B (in.)	C (in.)	D* (in.)	E (in.)	F (in.)	G (in.)	H (in.)	J (in.)	L (in.)	M (in.)	Floor Space (in.)
72	48½	36	3¼-32¾	6 - 42	6	36	6¾	8	3	12	48½ x 36

*Lateral head movement

ORDERING INFORMATION

Cap. (tons)	Type of Cylinder Used	Stroke	Cylinder Model	Order No.	Speed (in./min.)†††	Type Pump	Valve Type	Pump‡ Model	Prod.Wt. (lbs.)	
55	Single-Acting	6¾"	C556C	SPA556	4.5	.5	Air	2-Way Foot	PA6	804
55	Single-Acting	6¾"	C556C	SPM556	.23	.015	Hand	Load-Release	P159	814
55	Single-Acting	13¾"	C5513C	SPM5513	.665	.026	Hand	2-Way	P460	960
55	Single-Acting	6¾"	C556C	SPE556	21.7	1.5	Elec.	2-Way††	PE172	836
55	Single-Acting	13¾"	C5513C	SPE5513	21.7	1.5	Elec.	2-Way††	PE172	980
55	Single-Acting	13¾"	C5513C	SPE5513S	24.4	1.9	Elec.	3-Way†	PE213S	1,056
55	Double-Acting	13¾"	RD5513	SPE5513D	21.7	1.5	Elec.	4-Way	PE174	993
55	Double-Acting	13¾"	RD5513	SPE5513DS	66.1	5.4	Elec.	4-Way†	PQ604S	1,114

* Frame is shipped assembled.

† Solenoid valve with 24 volt remote control hand switch.

†† Holds pressure with motor shut off. Also has an automatic dump setting. Furnished with a 10' remote motor control.

††† Typical performance based on 100 psi and 10,000 psi pump specifications. Actual speeds may vary with operating conditions.

‡ Pump standard with press. Other Power Team pumps can be substituted. dBA at idle and 10,000 psi: PE172—67/81; PE21 Series—70; PQ60—74/76; measured at 3 foot distance, all sides.

PRESS ACCESSORIES

Page 144-145

www.powerteam.com

139

SHOP EQUIPMENT