

Press H FRAME

Open Throat & Economy Press 25 Ton

Presses

SHOP EQUIPMENT

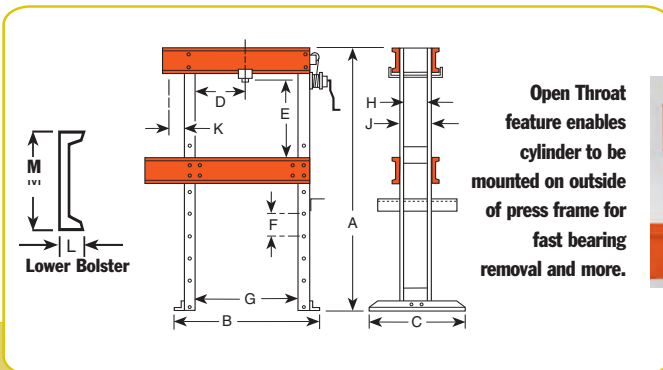

OPEN THROAT PRESSES

- Design permits use as both "H" frame and "C" frame press; cylinder can be mounted on frame extension to handle jobs which won't fit between uprights.
- Open throat press models are also available with remote control to enable the operator to view work from all sides with fingertip control of cylinder piston travel.
- Off-center pressing loads of full capacity can be applied across entire width of frame.

ECONOMY PRESSES

- Rugged, yet reasonably priced. Handles many "big press" tasks, and perfect for many of the "in-between" jobs you see almost daily. (Note: stroke length limited to 6¹/₄" on economy models.)

FEATURES OF BOTH OPEN THROAT AND ECONOMY PRESSES

- Press bed height easily adjustable with winch. Bed will not drop when handle is released.
- Choice of power sources for rapid cylinder advance: two-speed hydraulic hand pump, electric/hydraulic or air/hydraulic.

PUMP ELECTRICAL SPECIFICATIONS

PE17 Series – 1/2 hp, 115 volt, 60 cycle, single phase.

PE21 Series – 1 hp, 115 volt, 60 cycle, single phase.

Both pumps available in 230 volt, 50 cycle, add suffix "-220" to order no.

DIMENSIONS

A (in.)	B (in.)	C (in.)	D* (in.)	E (in.)	F (in.)	G (in.)	H (in.)	J (in.)	K (in.)	L (in.)	M (in.)	Floor Space (in.)
68	43	28	3 - 29	6 ⁷ / ₈ - 43 ³ / ₈	4 ¹ / ₂	32	5 ¹ / ₂	6 ¹ / ₂	7	2 ¹ / ₂	8	43 x 28

*Lateral head movement

ORDERING INFORMATION

Cap. (tons)	Type of Cylinder Used	Stroke	Cylinder Model	Order No.	Speed (in./min.)††† Advance	Pressing	Type Pump	Valve Type	Pump‡ Model	Prod.Wt. (lbs.)
"Open Throat" presses										
25	Single-Acting	14 ¹ / ₄ "	C2514C	SPA2514	9.8	1.2	Air	2-Way Foot	PA6	683
25	Single-Acting	14 ¹ / ₄ "	C2514C	SPM2514	.49	.03	Hand	Load-Release	P159	693
25	Single-Acting	14 ¹ / ₄ "	C2514C	SPE2514	46.6	3.3	Elec.	2-Way††	PE172	665
25	Single-Acting	14 ¹ / ₄ "	C2514C	SPE2514S	52	4.0	Elec.	3-Way†	PE213S	759
25	Double-Acting	14 ¹ / ₄ "	RD2514	SPE2514DS	52	4.0	Elec.	4-Way†	PE214S	787
"Economy" presses										
25	Single-Acting	6 ¹ / ₄ "	C256C	SPA256	9.8	1.2	Air	2-Way Foot	PA6	578
25	Single-Acting	6 ¹ / ₄ "	C256C	SPM256	.129	.129	Hand	Load-Release	P59	595
25	Single-Acting	6 ¹ / ₄ "	C256C	SPE256	46.6	3.3	Elec.	2-Way††	PE172	607

† Solenoid valve with 24 volt remote control hand switch.

†† Holds pressure with motor shut off. Also has an automatic dump setting. Furnished with a 10' remote motor control.

††† Typical performance based on 100 psi and 10,000 psi pump specifications. Actual speeds may vary under operating conditions.

‡ Pump standard with press. Other Power Team pumps can be substituted. dBA at idle and 10,000 psi: PE172-67/81 dBA; PE21-70 dBA measured at 3 foot distance, all sides.