

H Frame Presses

100 Ton Presses

SHOP EQUIPMENT



- Cylinder workhead glides across upper frame on rollers, locks in place for off-center pressing jobs. May be used horizontally for special pressing applications with user-supplied supports.
- Press bed is raised and lowered by winch which locks in place for insertion of bed retaining pins. Upper bolster can be lowered 8" for convenient positioning on repetitive jobs.
- Generous "daylight" of 42" x 50" accommodates bulky work pieces, uprights are placed for easy side entry of bars or shafts for straightening or bending.
- Choice of single- or double-acting cylinder. Hydraulic pump options include: 2-speed hand pump with large 2-gallon reservoir, PE172 electric/hydraulic pump or "PQ" series "Quiet" electric/hydraulic pump with low noise level.



PUMP ELECTRICAL SPECIFICATIONS

- PE17 Series** – 1/2 hp, 115 volt, 60 cycle, single phase. Also available in 230 volt, 50 cycle, add suffix "-220" to order no.
- PQ60 Series** – 2 hp, 230 volt, 60 cycle, single phase. Available in 115 volt, 60 cycle and 230 volt, 50 cycle. To order 230 volt, 50 cycle, add suffix "-220" to order no. For 115 volt consult factory.
- PQ120 Series** – 3 hp, 460 volt, 60 cycle, three phase. Available in 220/380 volt, 50 cycle. To order 380 volt, 50 cycle, add suffix "-380" to order no.

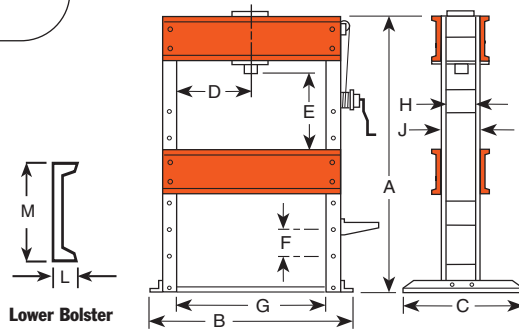

DIMENSIONS

A (in.)	B (in.)	C (in.)	D* (in.)	E (in.)	F (in.)	G (in.)	H (in.)	J (in.)	L (in.)	M (in.)	Floor Space (in.)
77 3/4	64	36	7 - 43	2 - 42	8	50	8	10	3 3/8	15	36 x 78 1/4

*Lateral head movement

ORDERING INFORMATION

Cap. (tons)†	Type of Cyl. Used	Stroke	Cylinder Model	Order No.	Speed (in./min.)†† Advance Pressing	Type Pump	Valve Type	Pump‡ Model	Prod. Wt. (lbs.)
100	Single-Acting	10 3/4"	C10010C	SPM10010	.356 in./stroke .01 in./stroke	Hand	3-way	P460	1,698
100	Single-Acting	10 3/4"	C10010C	SPE10010	35 11.5	Elec.	3-way	PQ603	1,795
100	Single-Acting	10 3/4"	C10010C	SPE10010R	.8	Elec.	2-way	PE172	1,690
100	Double-Acting	13 3/8"	RD10013	SPE10013DS	35 5.8	Elec.	4-way*	PQ1204S	1,886

† Frame is shipped assembled. *Solenoid valve with 24 volt remote control hand switch.

†† Typical performance based on 100 psi and 10,000 psi pump specifications. Actual speeds may vary under operating conditions.

‡ Pump standard with press. Other Power Team pumps can be substituted.

dBA at idle and 10,000 psi: PE172—67/81; PQ60—74/76; PQ120—73/78. Measured at 3 foot distance, all sides.