

DIRECTIONAL CONTROLE CETOP 3 IN ACCORDANCE WITH 2014/34/UE ATEX DIRECTIVE

2014/34/UE ATEX EC DIRECTIVE (EXPLOSIVE ATMOSPHERE)

INTRODUCTION

Since 30/06/2003 products introduced into the market (or started-up) inside the EU, destined to be used in potentially explosive environments, must be in compliance with the 2014/34/UE Directive through special marking. The directive regarding ATEX products 2014/34/UE is therefore the regulation instrument that the European Union uses to obtain legislative harmonisation between the States and guarantee free circulation of goods inside the European Community itself.

The directive affirms that to eliminate obstacles from commerce it is necessary to guarantee a high level of protection and, with this aim, define the essential requirements on the subject of safety and health. The dispositions base themselves on the principle of the "new approach" (NA), for which the essential safety requirements of products must be established depending on the risk evaluation concurrent at the time of their use.

The 2014/34/UE Directive is applied to the manufacture specifications of all those products (electrical and not) destined to be used in potentially explosive environments caused, by the dangers deriving from the presence of dust or gas, with the scope of reducing the risk of use that could be derived.

The term **product** refers to appliances, protection systems, devices, components and relative combinations, as defined in 2014/34/UE Directive.

The term **appliances** intends machines, materials, fixed or mobile devices, control elements, instruments detection and prevention systems. Alone or combined these are destined for production, transport, deposit, measurement, adjustment and conversion of energy, and to the transformation of material and which, by way of the powerful triggering sources, risk causing an explosion. As a consequence, even intrinsically safe appliances re-enter within the field of application of the directive.

The combination of two or more appliance parts, as well as any other components, makes up a whole unit that can be considered a product and therefore re-enters within the field of application of the 2014/34/UE Directive. If the whole unit requires adequate **installation** (therefore it is not immediately ready for use) the attached instructions should guarantee maintenance of compliance to the 2014/34/UE Directive on installation, without further evaluations of conformity. The installer must follow the instructions correctly.

When a combination of appliances leads to a **plant** this may not re-enter within the field of application of the directive. Each part must be certified and in compliance with the directive (as well as being subject to the relative evaluation of conformity, EC marking, etc.).

The plant manufacturer must therefore presume the conformity of the various components (each supplied with conformity certificate released by the respective manufacturer) and limit their evaluation only to any additional risks that become important in the final combination. Nevertheless, if the plant manufacturer inserts parts without EC marking or components not supplied with the certificate it will be obligatory to carry out further conformity evaluation of the whole unit.

The 2014/34/UE Directive envisions **obligations of the person** who introduces products into the market and/or starts them up, whether they are manufacturer's, his agent's, importer's or any other responsible person. The dispositions and obligations envisioned by the directive for **introduction into the market** have been applied, since 30 June 2003, to every individual product, independently from the date and place of manufacture. It is the manufacturers responsibility to guarantee conformity of all products, where these re-enter within the field of application of the directive.

The directive does not govern the use of the appliances; rather it establishes that the products can only be used if in compliance with safety requirements at the time of their introduction into the market or of their start-up. "**Start-up**" means the first use of the products subject of the 2014/34/UE Directive on EU territory by a final user. Nevertheless, a product that is immediately ready for use and does not need assembly or installation, and whose distribution conditions (deposit, transport, etc.) are not important for performance, is considered started-up at the time of introduction into the market.

Among the main potential causes/sources of triggering an explosion, such as sparks, flames, electric arcs etc., **maximum surface temperature** also plays an important role. The dispositions of the directive establish evaluation criteria for the maximum temperature admissible depending on the type of explosive atmosphere in which the appliance must operate.

For environments characterised by the presence of **gas-air**, some temperature values are supplied to which the appliances must refer. They are indicated by the letter T followed by a number. The criterion to apply is that for which the temperature of the appliance must never exceed 80% of the value indicated for its own category.

For environments characterised by the presence of **dust-air**, to prevent setting on fire of the airborne dust, the surface temperature of the appliances must be decidedly lower than the predictable temperature of catching fire of the air+dust mixture. Therefore, during planning the maximum working surface temperature must be declared directly (in degrees centigrade).

Increases in temperature deriving from an accumulation of heat and chemical reactions must also be taken into consideration. The thickness of the deposited layer of dust must also be considered and, if necessary, limit the temperature, to prevent an accumulation of heat.

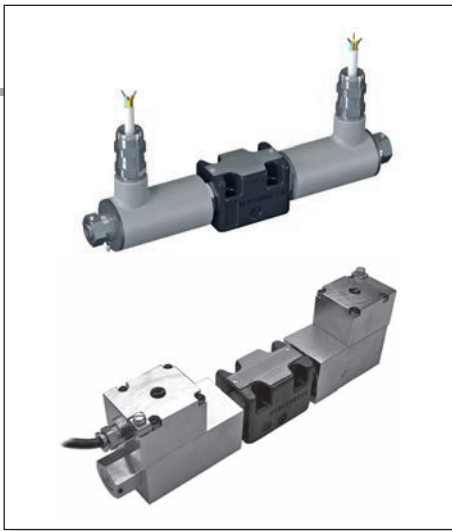

ATEX DIRECTIVE	CAP. I • 23
ATEX CLASSIFICATION	CAP. I • 24
SERIES AD3XD...	CAP. I • 25
SERIES AD3XG...	CAP. I • 29

1

CLASSIFICATIONS OF AREA - MIX - GROUP AND RELATIVE CATEGORY – ACCORDING TO ATEX DIRECTIVES

1

The 2014/34/UE Directive is a “new approach” directive based on risk analysis. Its objective is to minimise the risks deriving from the use of some products indoors or in relation to a potentially explosive atmosphere. The probability of an explosive atmosphere manifesting must be considered not only as “one-off” or from a static point of view: all operative conditions that can derive from the transformation process must be taken into consideration.

- An **explosive atmosphere** for the 2014/34/UE Directive is made up from a mixture of inflammable substances (as gas, vapours, mists and dust), with air, in determined atmospheric conditions in which, after triggering, the combustion propagates together with the unburned mixture.

- An atmosphere susceptible to transforming into an explosive atmosphere because of local and/or operative conditions is defined **potentially explosive atmosphere**.

Explosive atmospheres are not only formed in the presence of obviously dangerous substances such as fuel, solvents etc., but also in the presence of apparently harmless products such as wood dust, metal dusts, flour, grain, sugar etc. Therefore it can concern not only industries in the chemical or oil industry sectors, but also industries in the foodstuffs, textile, manufacturing etc.. It is important to consider that to re-enter within the 2014/34/UE Directive a product must be applied in presence of one or more of the characteristic elements listed above: *presence of inflammable substances and air, in atmospheric conditions that favour the propagation of combustion*. The directive does not define the atmospheric conditions itself. The relative norms indicate a temperature range, but this does not exclude that the products may be planned and evaluated specifically to occasionally function outside of this range, introducing the opportune construction transformations.

To define a **conformity evaluation procedure** adequate for the directive, the Manufacturer must, on the basis of the declared use, establish the products functioning conditions (this means to say, envision the type of working area, the type of explosive mixture with which it will come into contact and the level of probability that an explosive atmosphere verifies itself); successively he must establish to which Group the product belongs and individualise the category inside the Group.

With the Atex 99/92/EC Directive (For the safety of workers) the working conditions in which products in compliance with Atex 99/92/EC Directive will function are indicated here. These are expressed in “**Areas**” and defined according to the level of probability that a potentially explosive atmosphere is verified, respectively for every type of atmosphere (gas-air mix or dust-air mix).

Area 0 and 20 Places in which an explosive atmosphere is constantly present or present for long periods or frequently.

Area 1 and 21 Places in which an explosive atmosphere is probable. It is verified in normal functioning and exercise conditions.

Area 2 and 22 Places in which an explosive atmosphere has low probability of being verified or, if it occurs only lasts for a brief period of time.

GAS-AIR-TYPE EXPLOSIVE MIXTURE (G)

The products destined to work in environments characterised by this type of explosive atmosphere will be respectively indicated for Area **0, 1 or 2** depending on the Group and category of origin (see below) and are marked with the letter G.

DUST-AIR-TYPE EXPLOSIVE MIXTURE (D)

The products destined to work in environments characterised by this type of explosive atmosphere will be respectively indicated for Area **20, 21 or 22** depending on the Group and category of origin (see below) and are marked with the letter D.

GROUP I

Includes the appliances destined to be used in underground jobs in the mines and their surface plants, exposed to the risk of the release of firedamp and/or combustible dust. The subdivision into categories depends on the fact if the power supply must be interrupted or not if an explosive atmosphere manifests due to a mixture of air and gas, vapours mists (D) or a mixture of air and dust (G).

Category **M1 Very high protection level**. These products must be able to remain operative, for safety reasons, in the presence of an explosive atmosphere and present specific performances or protection configurations for breakdown in case of explosion.

Category **M2 High protection level**. The power supply to these products must be interrupted in the presence of an explosive atmosphere. Protection means must be incorporated to guarantee the level of protection during normal functioning and also in oppressive working conditions or resulting from great stress.

GROUP II

Includes appliances destined to be used in different environments (from the mines) in which there is a probability that an explosive atmosphere manifests itself. Their subdivision into categories depends on two factors: the place, where the product will be used and if the probability that a potentially explosive atmosphere, owing to the mixture of air and gas, vapours, mists (D) and the mixture of air and dust (G), comes about in a constant or occasional manner and if it does occur, does this possibility remain for long or brief period of time.

Category 1 Very high protection level. These products must be planned to function in compliance with operative parameters established by the Manufacturer in environments in which there is a high probability that explosive atmospheres are always detected or manifest often or for long periods of time. They must present specific performances or protection configurations for breakdown in case of explosion.

Category 2 High protection level. These products must be planned to function in compliance with operative parameters established by the Manufacturer in environments in which there is a high probability that explosive atmospheres can manifest. Protection against explosions relative to this category must function in a way to guarantee the required safety level even in the presence of functioning defects of the appliances or in dangerous operative conditions, which frequently must be taken into consideration.

Category 3 Normal protection level. These products must be planned to function in compliance with operative parameters established by the Manufacturer in environments in which there is a slight probability that explosive atmospheres can manifest, and however only rarely or for a brief period of time. This type of product belonging to the category in question must guarantee the safety level required in normal functioning conditions.

AD3XD... DIRECTIONAL CONTROLE CETOP 3 IN ACCORDANCE WITH 2014/34/UE ATEX DIRECTIVE

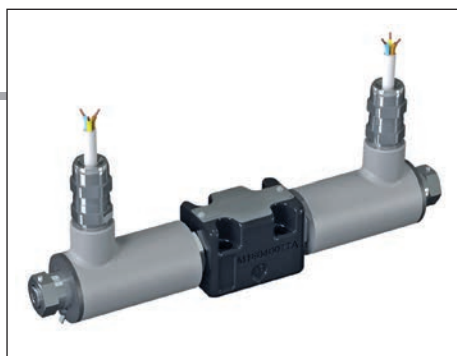

**SOLENOID VALVES FOR USE IN WORKPLACES WHERE EXPLOSIVE ATMOSPHERES
MAY OCCUR DUE TO THE PRESENCE OF GAS, VAPOUR OR MIST AND DUST.**

1

AD3XD...	
ATEX DIRECTIVE	CAP. I • 23
ATEX CLASSIFICATION	CAP. I • 24
SERIES AD3XD...	CAP. I • 25
TECHNICAL SPECIFICATIONS	CAP. I • 25
ORDERING CODE	CAP. I • 25
TAB.1 ASSEMBLY	CAP. I • 26
TAB.2 VOLTAGES	CAP. I • 26
TAB.3 SPOOL	CAP. I • 26
LIMITS OF USE	CAP. I • 26
IDENTIFICATION NAMEPLATE	CAP. I • 27
SAFETY INSTRUCTIONS	CAP. I • 27
OVERALL DIMENSIONS	CAP. I • 28

AD3.XD solenoid valves are classified in:

Group II appliances (to be used in workplaces, apart from mines, where there is the probability of explosive atmospheres);

Category 2 (high protection level), for use in workplaces where it is probable that an explosive atmosphere may form in normal working conditions and classified by the presence of explosive mixtures of gas-dust type (letter **GD**) for zones **1, 2** and **21, 22**.

Group I (They are intended to be used in mines with gas firedamp);

Category M2 (high level of protection), they are intended for use in underground environment in mines and their surface installations, exposed to the likely risk of the release of firedamp and / or combustible dust under normal operating conditions.

These valves are therefore designed especially and manufactured in compliance with the ATEX 2014/34/UE Directive and according to European regulations EN 1127-1, EN 1127-2, EN 13463-1 and EN 13463-5.

Belonging to the "NG06 direction control" range, these valves are prepared for plate-mounting with attachment surface in compliance with UNI ISO 4401 - 03 - 02 - 0 - 94 (former CETOP R 35 H 4.2-4-03). They are activated electrically and the centre position is ensured by springs with gauged lengths, which once the pulse or command ceases, re-position the spool in the centre or at the end of travel position.

The coils used for these valves are subject to separate conformity certification, according to the ATEX Directive (EC-type). For further specifications, please consult the documents that are always supplied with the valve.

Before marking and marketing the valves of the AD3XD series, undergo tests and inspections according to the in-house Manufacturing System and to the Certified Company Quality System in compliance with ISO 9001:2008. All of the AD3XD valve series undergo 100% functional testing. These tests and inspections guarantee that the products sold comply with all the information reported in the Technical Specifications File registered and declared by marking with AD3X/ATEX/10.

ORDERING CODE

AD	Directional Control Valve
3	CETOP 3/NG06
XD	Solenoid valves built pursuant to ATEX Directive-2014/34/UE. With coils in explosion-proof version (Ex d) and IECEx conformity marked
**	Spools 01/02/03/04/16 (tab.3). For further hydraulic diagrams, contact our Customer Service
*	Assembly C / E / F / G / H (tab.1). For further assembly instructions, contact our Customer Service
*	Voltage (tab.2)
**	Variants 00 = None V1 = Viton LE = Emergency lever T6 = Suitable for temperature class I M2 Group T6 (<85°C) (mine)
2	Serial number

TECHNICAL SPECIFICATIONS

Description	AD3XD...	T6 version (mine)
Valve marking	CE Ex II 2GD/I M2 cT5	CE Ex II 2GD/I M2 cT6
Max. pressure on lines P/A/B	320 bar	320 bar
Max. pressure on line T (dynamic)	250 bar	250 bar
Max. flow rate	60 l/min	60 l/min
Max. excitation frequency	3 Hz	3 Hz
Duty cycle	100%ED	100%ED
Hydraulic fluids	mineral oils DIN 51524	mineral oils DIN 51524
Fluid viscosity	10 ÷ 500 mm ² /s	10 ÷ 500 mm ² /s
Fluid temperature (*)	-20°C ÷ +40°C	-20°C ÷ +40°C
Ambient temperature	-20°C ÷ +40°C	-20°C ÷ +40°C
Max. contamination level	NAS 1638: class 10 with filter β ₂₅ ≥ 75	NAS 1638: class 10 with filter β ₂₅ ≥ 75
Weight (one solenoid)	2,37 kg	2,37 kg
Weight (two solenoids)	3,82 kg	3,82 kg
Solenoid rated power:	6,5 ÷ 11W	
Degree of protection:	IP 67	
Power supply tolerance:	±10%	
Power supply cable:	standard length 3 m with cable gland	
Solenoid marking (**):	consult documents supplied with solenoid	
Surface temperature:	function of the power. Consult documents supplied with solenoid.	

(*) For use with different hydraulic fluids, which do not constitute an effective ignition source in potentially explosive atmospheres IIC across the range of temperatures and pressures required by the unit marking, contact our technical department.

(**) Solenoid is provided with marking for protection class according to Explosion Protection Directive ATEX-2014/34/UE and IECEx certificate of conformity mark.

AD3XD... DIRECTIONAL CONTROLE CETOP 3

IN ACCORDANCE WITH 2014/34/UE ATEX DIRECTIVE

1

TAB.1 ASSEMBLY

STANDARD	
C	Two solenoids centred
E	One solenoid (side A)
F	One solenoid (side B)
Specials (with increased price)	
G	
H	

TAB.2 VOLTAGES

AC Voltage	
A	24V 50Hz/60Hz
C	110V 50Hz/60Hz
D	220V 50Hz/60Hz
I	230V 50Hz/60Hz
DC Voltage	
L	12V
M	24V
P	110V
N	48V

The tension symbol is always printed on the nameplate.

TAB.3 SPOOL

Two solenoids - Assembly C			
Spool type		Covering	Transient position
01		+	
02		-	
03		+	
04*		-	

One solenoid - Assembly E			
Spool type		Covering	Transient position
01		+	
02		-	
03		+	
04*		-	
16		+	

One solenoid - Assembly F			
Spool type		Covering	Transient position
01		+	
02		-	
03		+	
04*		-	
16		+	

(*) spool with increased price

LIMITS OF USE (MOUNTING C-E-F)

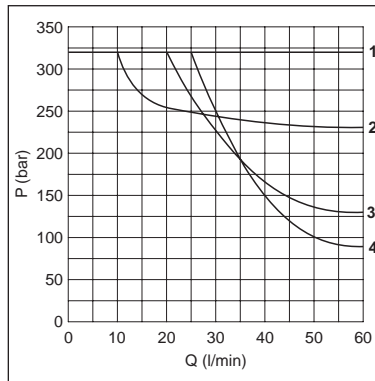

NOTE: the operating limits shown are valid for C fittings, E, F.

Spool type	Curve
01	2
02	1
03	3
04	4
16	1

The tests have been carried out with solenoids at operating temperature with a voltage 10% less than rated voltage with a fluid temperature of 40°C. The fluid used was a mineral oil with a viscosity of 46 mm²/s at 40°C. The values in the diagram refers to tests carried out with the oil flow in two direction simultaneously (e.g.. from P to A and in the same time B to T).

In cases where valves 4/2 e 4/3 were used with the flow in one direction only, the limits of use could have variations which may even be negative.

PRESSURE DROPS

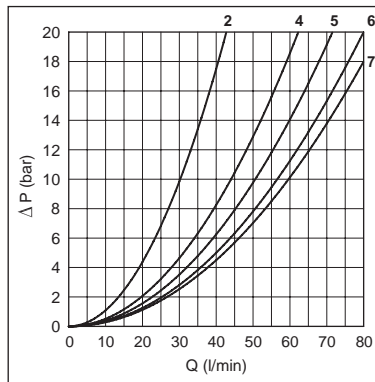

The diagram at the side shows the pressure drop curves for spools during normal usage. The fluid used is a mineral oil with a viscosity of 46 mm²/s at 40°C; the tests have been carried out at a fluid temperature of 40°C. For higher flow rates than those in the diagram, the losses will be those expressed by the following formula:

$$\Delta p_1 = \Delta p \times (Q_1/Q)^2$$

where Δp will be the value for the losses for a specific flow rate Q which can be obtained from the diagram, Δp_1 will be the value of the losses for the flow rate Q₁ that is used.

Spool type	Connections				
	P→A	P→B	A→T	B→T	P→T
01	5	5	5	5	
02	7	7	7	7	6
03	5	5	6	6	
04	2	2	2	2	4
16	5	5	4	4	

Curve No.

AD3XD... DIRECTIONAL CONTROLE CETOP 3

IN ACCORDANCE WITH 2014/34/UE ATEX DIRECTIVE

IDENTIFICATION NAMEPLATE AND MARKING

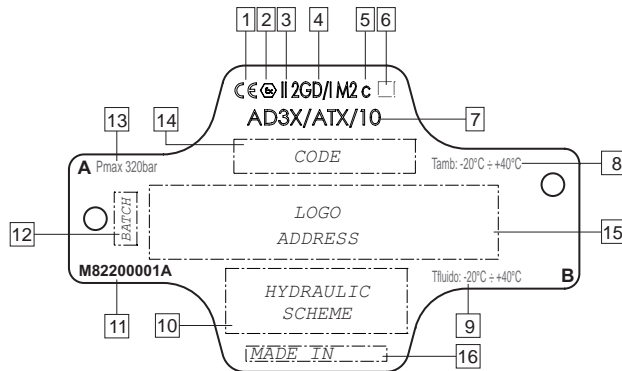

All the solenoid valves are supplied with **identification nameplate and Declaration of conformity** subject to Directive 2014/34/UE.

The identification nameplate bears the main technical specifications related to the functional and constructional characteristics of the valve and **must therefore be kept intact and visible**.

1	CE	Conformity to European Directive
2	Ex	Conformity to ATEX Directive 2014/34/UE
3	II 2 I	Group II (surface places) Group I (mine) Category 2 (high protection)
4	GD M	Explosive atmosphere: GD: presence of gas, vapour or mist and combustible dust M: presence of firedamp atmospheres
5	c	Constructional safety
6	T*	Temperature class: T5 (T _{sur} < 100 °C) T6 (T _{sur} < 85 °C) T6 version (mine)
7	AD3X/ ATX/10	Reference to Technical File registered c/o Notified Body
8	T amb	Working ambient temperature: - 20°C ÷ + 40°C series AD3XD

9	T fluid	Working fluid temperature: - 20°C ÷ + 40°C series AD3XD
10	HYDRAULIC SCHEME	Type of hydraulic control performed by the valve
11	M82200001A	Nameplate code
12	BATCH	Reference number of technical order (batch)
13	Pmax 320 bar	Max working pressure
14	CODE	Complete reference number of valve ordering code
15	LOGO ADDRESS	Logo and address
16	MADE IN	Preferential origin

SAFETY INSTRUCTIONS

- Read the instruction handbook supplied with the valves carefully before installation. All maintenances must be carried out following the instructions given in the manual.
- The AD3XD series valves must be installed and serviced in compliance with plant engineering and maintenance regulations for workplaces classified against the risk of explosion due to the presence of gas and dust and gas (for example: CEI EN 60079-14, CEI EN 60079-17, CEI EN 61241-14, CEI EN 61241-17 or other national regulations/standards).
- The valves must be connected to earth using the special anti-loosening and anti-rotation connection element.
- For all safety aspects related to the use of the coils, consult the relative use and maintenance instructions. The electrical appliances/components must not be opened when live.
- The user must periodically inspect, based on the conditions of use and the substances used, the presence of scale, dirt, the state of wear and tear and correct efficiency of the valves.

Attention: all installation and maintenance jobs must be carried out by qualified personnel.

AD3XD... DIRECTIONAL CONTROLE CETOP 3

IN ACCORDANCE WITH 2014/34/UE ATEX DIRECTIVE

OVERALL DIMENSIONS

1

AD3XD...

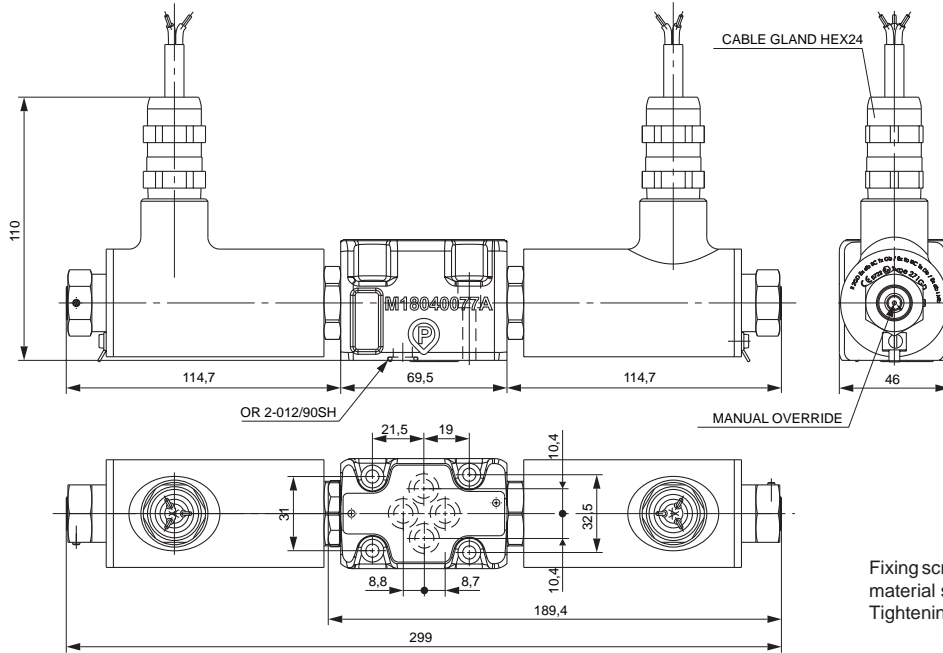

Fixing screws UNI 5931 M5x30 with material specification min. 8.8
Tightening torque 5 Nm / 0.5 kgm

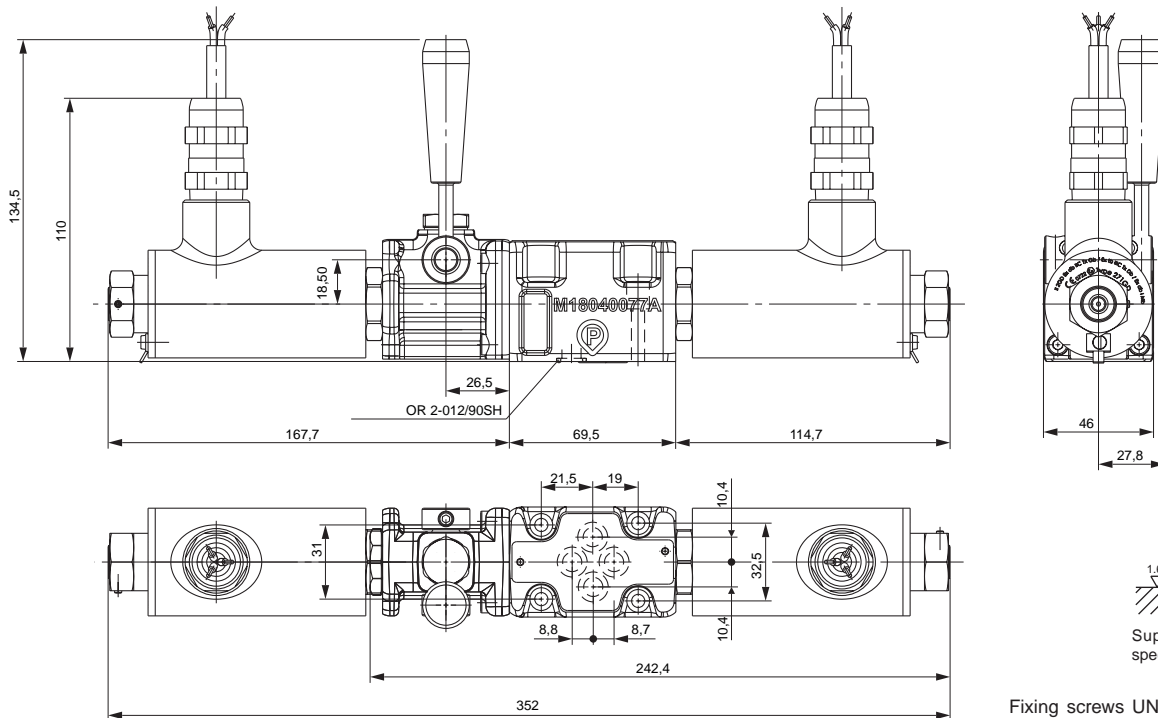

Fixing screws UNI 5931 M5x30 with material specification min. 8.8
Tightening torque 5 Nm / 0.5 kgm

AD3XG... DIRECTIONAL CONTROLE CETOP 3 IN ACCORDANCE WITH 2014/34/UE ATEX DIRECTIVE

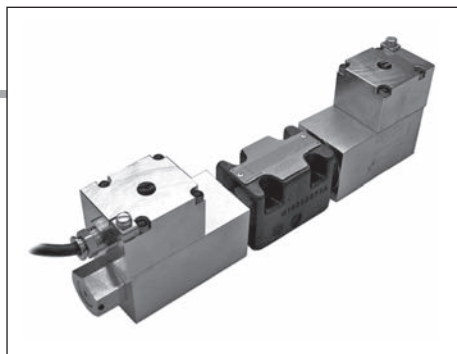

**SOLENOID VALVES FOR USE IN WORKPLACES WHERE EXPLOSIVE ATMOSPHERES
MAY OCCUR DUE TO THE PRESENCE OF GAS, VAPOUR OR MIST AND DUST.**

1

AD3XG...

ATEX DIRECTIVE	CAP. I • 23
ATEX CLASSIFICATION	CAP. I • 24
SERIES AD3XG...	CAP. I • 29
TECHNICAL SPECIFICATIONS	CAP. I • 29
ORDERING CODE	CAP. I • 29
TAB.1 ASSEMBLY	CAP. I • 30
TAB.2 VOLTAGES	CAP. I • 30
TAB.3 SPOOL	CAP. I • 30
LIMITS OF USE	CAP. I • 30
IDENTIFICATION NAMEPLATE	CAP. I • 31
SAFETY INSTRUCTIONS	CAP. I • 31
OVERALL DIMENSIONS	CAP. I • 32

AD3XG solenoid valves are classified in:

Group II appliances (to be used in workplaces, apart from mines, where there is the probability of explosive atmospheres);

category 2 (high protection level), for use in workplaces where it is probable that an explosive atmosphere may form in normal working conditions and classified by the presence of explosive mixtures of gas-dust type (letter **GD**) for zones **1, 2** and **21, 22**.

These valves are therefore designed especially and manufactured in compliance with the ATEX 2014/34/UE Directive and according to European regulations EN 1127-1, EN 1127-2, EN 13463-1 and EN 13463-5.

Belonging to the "NG06 direction control" range, these valves are prepared for plate-mounting with attachment surface in compliance with UNI ISO 4401 - 03 - 02 - 0 - 94 (former CETOP R 35 H 4.2-4-03). They are activated electrically and the centre position is ensured by springs with gauged lengths, which once the pulse or command ceases, re-position the spool in the centre or at the end of travel position.

The coils used for these valves are subject to separate conformity certification, according to the ATEX Directive (EC-type). For further specifications, please consult the documents that are always supplied with the valve.

Before marking and marketing the valves of the AD3XG series, undergo tests and inspections according to the in-house Manufacturing System and to the Certified Company Quality System in compliance with ISO 9001:2008. All of the AD3XG valve series undergo 100% functional testing. These tests and inspections guarantee that the products sold comply with all the information reported in the Technical Specifications File registered and declared by marking with AD3X/ATEX/10.

ORDERING CODE

AD	Directional Control Valve
3	CETOP 3/NG06
XG	Solenoid valves built pursuant to ATEX Directive-2014/34/UE. With coils in explosion-proof version (Ex d) and IECEx conformity marked.
**	Temperature Class T4 (T _{sur} < 135 °C) T6 (T _{sur} < 85 °C)
**	Spools 01/02/03/04/16 (tab.3). For further hydraulic diagrams, contact our Customer Service
*	Assembly C / E / F / G / H (tab.1). For further assembly instructions, contact our Customer Service
*	Voltage (tab.2)
**	Variants 00 = None V1 = Viton LE = Emergency lever
1	Serial number

TECHNICAL SPECIFICATIONS

Description	AD3XG T4...	AD3XG T6...
Valve marking	CE Ex II 2 GD cT4	CE Ex II 2 GD cT6
Max. pressure on lines P/A/B (1)	350 bar	350 bar
Max. pressure on line T (dynamic) (2)	250 bar	250 bar
Max. flow rate	80 l/min	80 l/min
Max. excitation frequency	3 Hz	3 Hz
Duty cycle	100%ED	100%ED
Hydraulic fluids	mineral oils DIN 51524	mineral oils DIN 51524
Fluid viscosity	10 ÷ 500 mm ² /s	10 ÷ 500 mm ² /s
Fluid temperature (3)	-30°C ÷ +70°C	-30°C ÷ +70°C
Ambient temperature	-40°C ÷ +80°C	-40°C ÷ +50°C
Max. contamination level	ISO 4406:1999: class 21/19/16	ISO 4406:1999: class 21/19/16
(filter β ₂₅ ≥ 75)	NAS 1638: class 10	NAS 1638: class 10
Weight (one solenoid)	3 kg	3 kg
Weight (two solenoids)	5 kg	5 kg
Coil rated power	8,5 W	8,5 W
Degree of protection	IP 67	IP 67
Power supply tolerance	±10%	±10%
Power supply cable	standard length 3m with cable gland	standard length 3m with cable gland
Coil marking (4):	consult documents supplied with coil	consult documents supplied with coil
Surface temperature	< 135°C	< 85°C

(1) Dynamic pressure allowed on P for 800.000 cycles.

(2) Pressure dynamic allowed for 1 million of cycles.

(3) AD3XG valves have been certified for minimum fluid temperatures up to -30°C. Please contact our Technical department for applications at fluid temperatures < -25°C.

(4) Coil is provided with marking for protection class according to Explosion Protection Directive ATEX-2014/34/UE and IECEx certificate of conformity mark.

AD3XG... DIRECTIONAL CONTROLE CETOP 3

IN ACCORDANCE WITH 2014/34/UE ATEX DIRECTIVE

1

TAB.1 ASSEMBLY

STANDARD	
C	Two solenoids centred
E	One solenoid (side A)
F	One solenoid (side B)
Specials (with increased price)	
G	
H	

TAB.2 VOLTAGES

AC Voltage for AD3XG	
A	24V 50Hz/60Hz
B	48V 50Hz/60Hz
C	110V 50Hz/60Hz
D	220V 50Hz/60Hz
I	230V 50Hz/60Hz
DC Voltage for AD3XG	
L	12V
M	24V
P	110V
N	48V
U	36V
6	60V
G	125V

The tension symbol is always printed on the nameplate.

TAB.3 SPOOL

Two solenoids - Assembly C			
Spool type	Covering	Transient position	
01	+		
02	-		
03	+		
04*	-		

One solenoid - Assembly E			
Spool type	Covering	Transient position	
01	+		
02	-		
03	+		
04*	-		
16	+		

One solenoid - Assembly F			
Spool type	Covering	Transient position	
01	+		
02	-		
03	+		
04*	-		
16	+		

(*) spool with increased price

LIMITS OF USE (MOUNTING C-E-F)

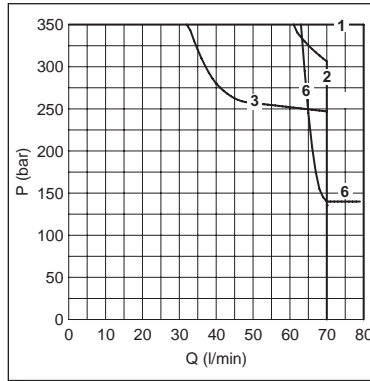

NOTE: The limit of use are valid for C, E, F assembly.

Spool type	Curve
01	1
02	1
03	3
04	2
16	6

The tests have been carried out with solenoids at operating temperature with a voltage 10% less than rated voltage with a fluid temperature of 40°C. The fluid used was a mineral oil with a viscosity of 46 mm²/s at 40°C. The values in the diagram refers to tests carried out with the oil flow in two direction simultaneously (e.g.. from P to A and in the same time B to T).

In cases where valves 4/2 e 4/3 were used with the flow in one direction only, the limits of use could have variations which may even be negative.

PRESSURE DROPS

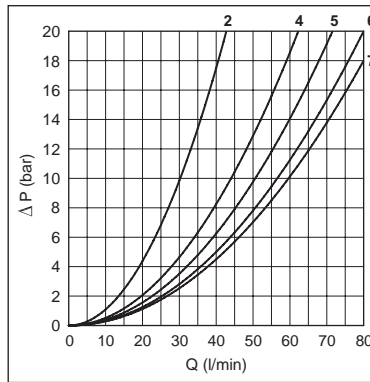

The diagram at the side shows the pressure drop curves for spools during normal usage. The fluid used is a mineral oil with a viscosity of 46 mm²/s at 40°C; the tests have been carried out at a fluid temperature of 40°C. For higher flow rates than those in the diagram, the losses will be those expressed by the following formula:

$$\Delta p_1 = \Delta p \times (Q_1/Q)^2$$

where Δp will be the value for the losses for a specific flow rate Q which can be obtained from the diagram, Δp_1 will be the value of the losses for the flow rate Q1 that is used.

Spool type	Connections				
	P→A	P→B	A→T	B→T	P→T
01	5	5	5	5	6
02	7	7	7	7	6
03	5	5	6	6	
04	2	2	2	2	4
16	5	5	4	4	

Curve No.

AD3XG... DIRECTIONAL CONTROLE CETOP 3

IN ACCORDANCE WITH 2014/34/UE ATEX DIRECTIVE

IDENTIFICATION NAMEPLATE AND MARKING

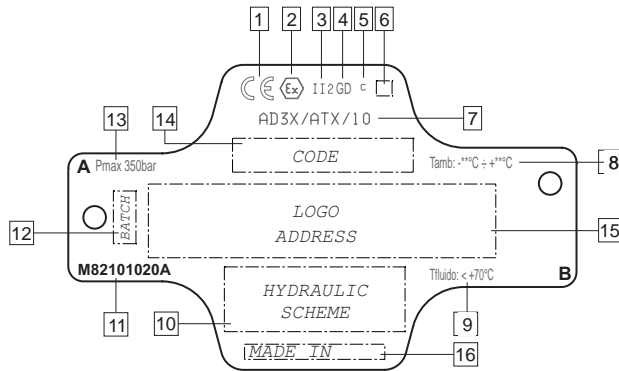

All the solenoid valves are supplied with **identification nameplate and Declaration of conformity** subject to Directive 2014/34/UE.

The identification nameplate bears the main technical specifications related to the functional and constructional characteristics of the valve and **must therefore be kept intact and visible**.

1	CE	Conformity to European Directive
2	Ex	Conformity to ATEX Directive 2014/34/UE
3	II 2	Group II (surface places) Category 2 (high protection)
4	GD	Explosive atmosphere: GD: presence of gas, vapour or mist and combustible dust
5	c	Constructional safety
6	T*	Temperature class: T4 (T _{sur} < 135 °C) series AD3XG T4 T6 (T _{sur} < 85 °C) series AD3XG T6
7	AD3X/ATX/10	Reference to Technical File registered c/o Notified Body
8	T amb	Working ambient temperature: - 40°C ÷ + 80°C series AD3XG T4 - 40°C ÷ + 50°C series AD3XG T6

9	T fluid	Working fluid temperature: - 30°C ÷ + 70°C series AD3XG
10	HYDRAULIC SCHEME	Type of hydraulic control performed by the valve
11	M82101020A	Nameplate code
12	BATCH	Reference number of technical order (batch)
13	Pmax 350 bar	Max. working pressure
14	CODE	Complete reference number of valve ordering code
15	LOGO ADDRESS	Logo and address
16	MADE IN	Preferential origin

SAFETY INSTRUCTIONS

- Read the instruction handbook supplied with the valves carefully before installation. All maintenances must be carried out following the instructions given in the manual.
- The AD3XG series valves must be installed and serviced in compliance with plant engineering and maintenance regulations for workplaces classified against the risk of explosion due to the presence of gas and dust and gas (for example: CEI EN 60079-14, CEI EN 60079-17, CEI EN 61241-14, CEI EN 61241-17 or other national regulations/standards).
- The valves must be connected to earth using the special anti-loosening and anti-rotation connection element.
- For all safety aspects related to the use of the coils, consult the relative use and maintenance instructions. The electrical appliances/components must not be opened when live.
- The user must periodically inspect, based on the conditions of use and the substances used, the presence of scale, dirt, the state of wear and tear and correct efficiency of the valves.

Attention: all installation and maintenance jobs must be carried out by qualified personnel.

AD3XG... DIRECTIONAL CONTROLE CETOP 3

IN ACCORDANCE WITH 2014/34/UE ATEX DIRECTIVE

OVERALL DIMENSIONS

1

AD3XG...

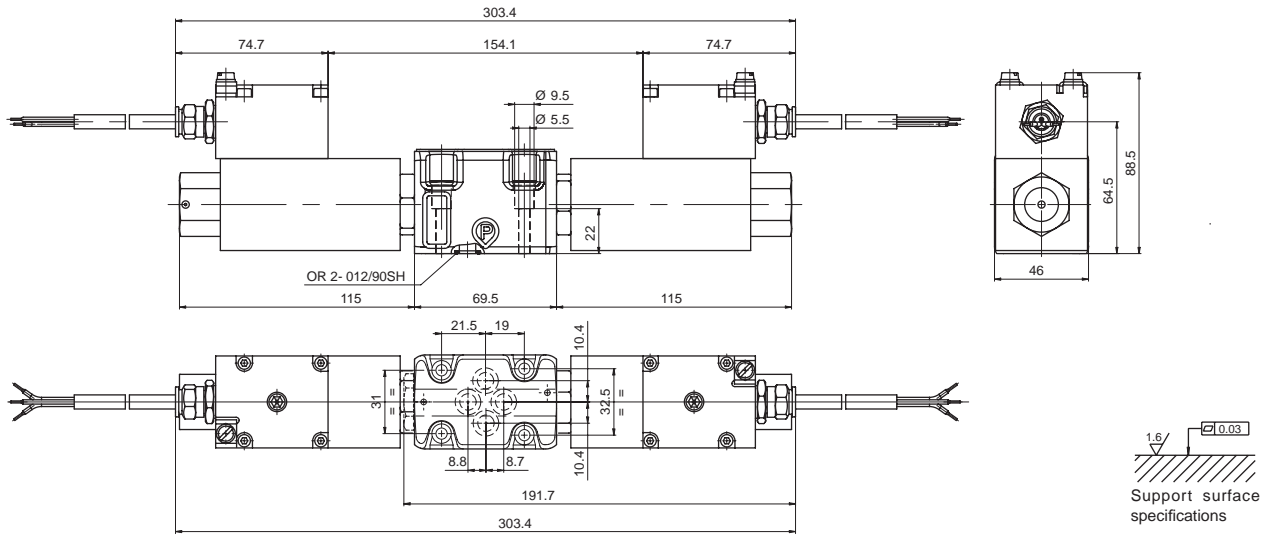

Fixing screws UNI 5931 M5x30
with material specification min. 8.8
Tightening torque 5 Nm / 0.5 kgm

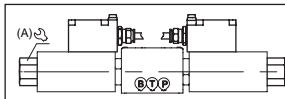

Should it be necessary to change the coils position, fastener ring nut A as described in the solenoid valve assembly instructions.

AD3XG...LE.

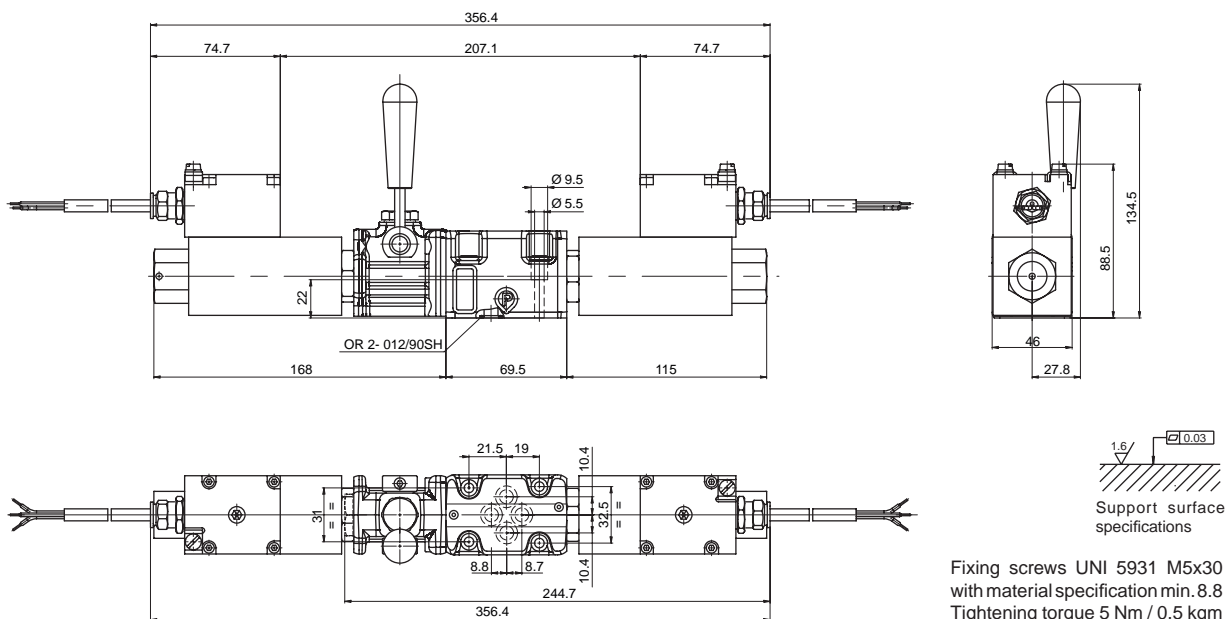

Fixing screws UNI 5931 M5x30
with material specification min. 8.8
Tightening torque 5 Nm / 0.5 kgm