

Valves type AD3.E...J* with spool movement speed control

1

These ON-OFF type valves are used a lower spool movement speed than usual for conventional solenoid valves is required to prevent impacts which could adversely affect the smooth running of the system. The system consist of reducing the transfer section for the fluid from one solenoid to the other by means of calibrated orifices.

- This version can only be used with a direct current (DC) and also involves a **reduction in the limits of use so that we suggest to always test the valve in your application**

- To order AD.3...J* version valves, specify the orifices code.

- The operation is linked to a minimum counter-pressure on T line (1 bar min.)

- The switching time referred to the spool travel detected by a LVDT transducer can vary for the NG6 valve from a minimum of 100 to a maximum of 300 ms depending on 5 fundamental variables:

- 1) Diameter of the calibrated orifices (see table)
- 2) Hydraulic power for clearance referring to flow and pressure values through valve
- 3) Spool type
- 4) Oil viscosity and temperature
- 5) Counter-pressure at T line

- Possible mountings: C / E / F / G / H

- 16 / 19 / 20 / 21 spools not planned for AD.3.E...J*

Max. pressure ports P/A/B	320 bar
Max. pressure port T (*)	250 bar
Max. flow	30 l/min
Max. excitation frequency	2 Hz
Duty cycle	100% ED
Fluid viscosity	10 ÷ 500 mm ² /s
Fluid temperature	-25°C ÷ 75°C
Ambient temperature	-25°C ÷ 60°C
Weight with one DC solenoid	1,65 Kg
Weight with two solenoids DC solenoids	2 Kg

(*) Pressure dynamic allowed for 2 millions of cycles.

CALIBRATED ORIFICES AVAILABLE		
ø (mm)	M4x4	Code
0.3	M89.10.0028	3S (J3+S1)*
0.4	M89.10.0029	JS (J4+S1)*
0.5	M89.10.0006	5S (J5+S1)*
0.6	M89.10.0030	6S (J6+S1)*

* Old code

OVERALL DIMENSIONS

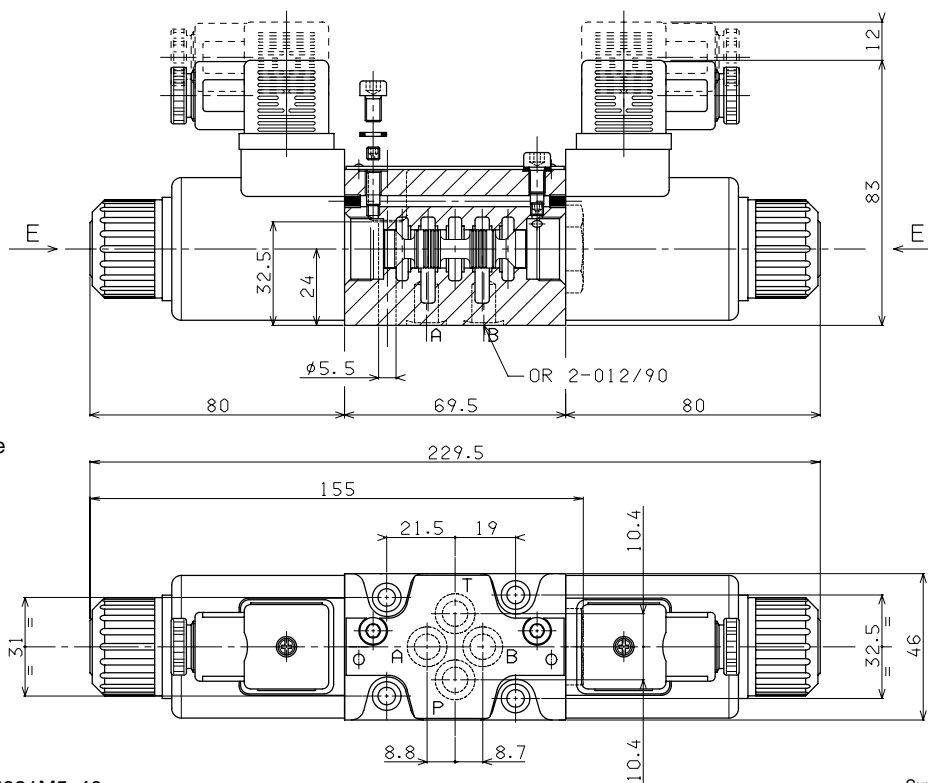

E = Manual override

Fixing screws UNI 5931M5x40
with material specifications min. 8.8
Tightening torque 5 Nm / 0.5 Kgm

Support plane specifications

